



BAUER

FOR A GREEN WORLD

OPERATING MANUAL

for

BAUER – CENTERLINER CLX 9000

with hose feed

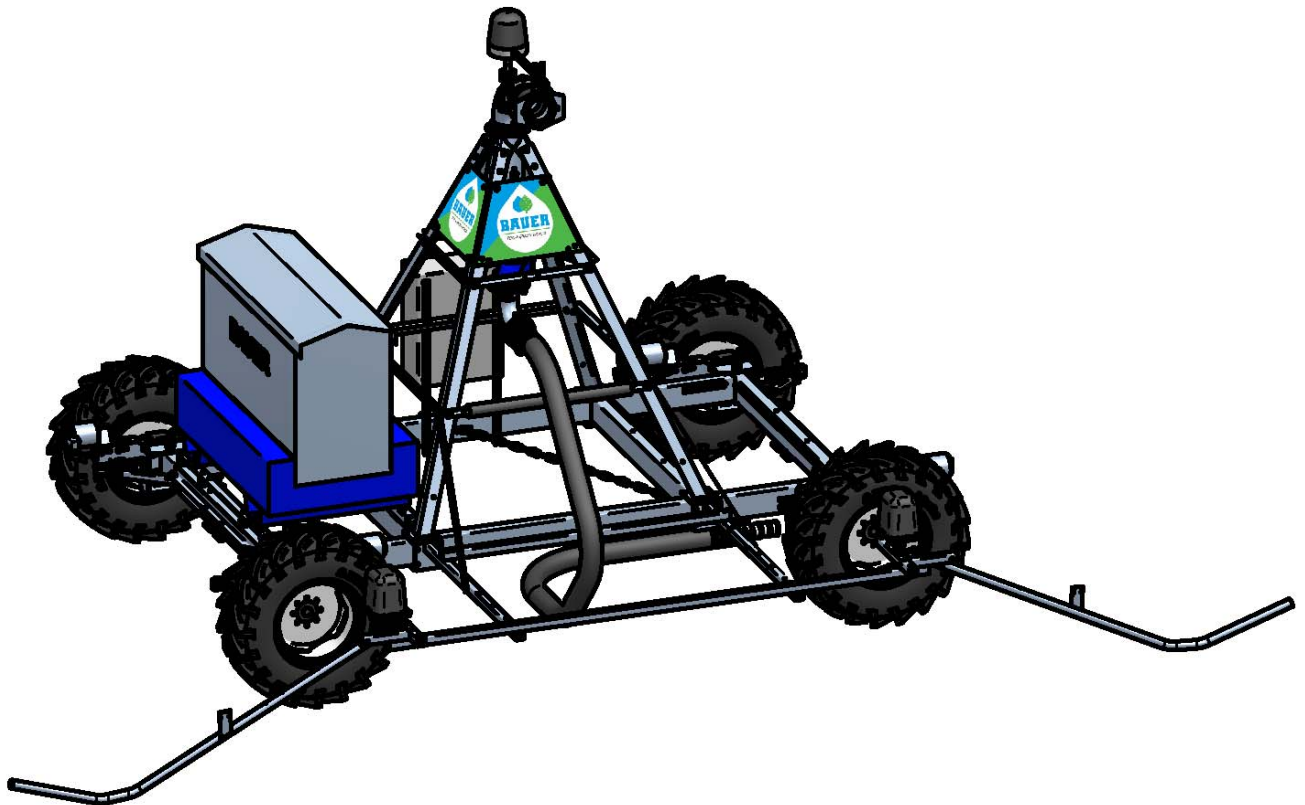



Introduction

Thank you for buying a BAUER CENTERLINER CLX 9000 !

The present **manual** is a very important document that describes how to operate and service **BAUER CENTERLINER CLX 9000**.

This manual describes the system as detailed as possible. If you need still more information, please contact your dealer or turn directly to **BAUER** in Voitsberg.

All information contained in the present manual is based on the latest product details available at the time of printing.

BAUER reserves the right to change without notice without assuming any liability!

BAUER CENTERLINER CLX 9000 is designed for highest performance safety and reliability provided it is operated in accordance with the present operating instructions.

Therefore you should study this manual thoroughly before starting your **BAUER CENTERLINER CLX 9000** !

Strictly observe all instructions pertaining to system handling, operation and service!

On this condition, **BAUER CENTERLINER CLX 9000** will operate to your satisfaction for many years!



Non-observance of this manual may cause personal injury or damage the equipment!

This manual is to be considered an integral part of **BAUER CENTERLINER CLX 9000**. Suppliers of both new and used systems are advised to put down in writing that they delivered the manual together with the system.

Please make this manual available to your staff. State the pump type and serial number of your **BAUER CENTERLINER CLX 9000** in all inquiries, correspondence, warranty problems, or parts orders.

We wish you a lot of success with BAUER CENTERLINER CLX 9000 !



Owner of the machine

This machine with the serial number	<input type="text"/>
Belongs to	
Name	
Address	
Residence	
Telephone number	
Dealer	
Bauer dealer	
Service technician	
Telephone number	



Handing over record

A duly test run has been done in the presence of the client or a nominated agent of the client. The client confirms by signing that the machine has been test run before taken over. A copy of the handing over record needs to be sent back to the company BAUER Ges.m.b.H.

Comments:

For the client

For the company BAUER GMBH



Product details

Date of delivery

Date of initial operation

Type	BAUER CENTERLINER CLX 9000		
Serial number		
Configuration of span		
Spans	fixed	towable	
Drive tower elec. swivelling	yes	no	
Booster pump	yes	no	
End gun	yes	no	
Equipment		
Linear guidance	Cable	Furrow	Induction
Water feeding	Hose		
Connecting hose	Diam	Length	
Generator unit		
Comments		
		
		

Manufacturer of the machine:

Röhren- und Pumpenwerk BAUER Ges.m.b.H.
Kowaldstrasse 2
A – 8570 Voitsberg
Tel.: +43 3142 200 – 0
Fax: +43 3142 200–320 / -340
e-mail: sales@bauer-at.com
www.bauer-at.com

Dealer:

Name:

Address:

.....

Tel. / Fax:



Index

1	GENERAL INSTRUCTIONS	1
2	WARNING SYMBOLS	2
3	GENERAL HINTS	3
4	GENERAL INSTRUCTIONS FOR SAFETY AND ACCIDENT PREVENTION	3
5	SAFETY PRECAUTIONS FOR CENTERLINER CLX 9000	4
6	TECHNICAL DESCRIPTION	5
6.1	CENTERLINER OPERATING MODES.....	5
6.1.1	LINEAR MODE.....	5
6.1.2	PIVOT MODE.....	5
6.1.3	AUTOMATIC INWARD SWIVELLING MODE.....	5
6.1.4	AUTOMATIC OUTWARD SWIVELLING MODE.....	6
6.1.5	AUTOMATIC INWARD SWIVELLING MODE AND AUTOMATIC CONTINUED TRAVEL IN LINEAR MODE.....	6
6.1.6	AUTOMATIC OUTWARD SWIVELLING MODE AND AUTOMATIC CONTINUED TRAVEL IN LINEAR MODE.....	6
6.1.7	AUTOMATIC OUTWARD / INWARD SWIVELLING MODE.....	7
6.2	COMPONENTS OF THE CENTERLINER.....	8
6.2.1	COMPONENTS OF THE BELOW GROUND GUIDANCE.....	9
7	USE OF CENTERLINER	10
7.1	PERMISSIBLE BENDING ANGLES.....	10
7.1.1	HORIZONTAL.....	10
7.1.2	INCLINATION.....	10
7.1.3	INCLINATION, VERTICAL ANGULAR DEVIATION.....	11
7.2	TRACK DETERMINATION AND MAINTENANCE.....	11
7.2.1	TRAVELLING DIRECTION.....	11
8	CENTERLINER MAIN CART	12
8.1	MAIN CART CLX / CLX-T.....	12
9	CONTROL PANEL	13
9.1	CONTROL PANEL SELECT PRO FOR CENTERLINER CLX.....	13
9.1.1	STANDARD BUILT-IN COMPONENTS.....	14
9.2	CONTROL PANEL SELECT PRO-G FOR CENTERLINER CLX.....	16
9.2.1	STANDARD BUILT-IN COMPONENTS.....	17
10	LINEAR CONTROL SYSTEM	19
10.1	FURROW GUIDANCE.....	19
10.2	CABLE GUIDANCE – ASSEMBLY AND SETTING.....	20
10.3	BELOW GROUND GUIDANCE.....	22
10.3.1	OSCILLATOR BOX, STEERING ANTENNAS, TRACK UNIT.....	22
10.3.2	BELOW GROUND CABLE.....	25
10.4	SETTING OF LINEAR CONTROL.....	26
10.5	SETTING OF STOP SWITCH.....	28
11	DIESEL GENERATOR UNIT	29
12	CENTERLINER CONTROL WITH ABSOLUTE ENCODER	30
12.1	INSTALLATION INSTRUCTIONS.....	30
12.2	ALIGNMENT OF THE CENTERLINER AND ADJUSTMENT OF THE LINEAR CONTROL SYSTEM.....	32
12.2.1	ALIGNMENT OF MAIN CART IN PARALLEL TO LINEAR GUIDANCE (<i>FURROW, CABLE</i>).....	32
12.2.2	ALIGNMENT OF SPANS AT 90° TO MAIN CART.....	32
12.2.3	ALIGNMENT OF MAIN CART / SPANS TO LINEAR GUIDANCE (<i>BELOW GROUND GUIDANCE</i>).....	33
13	ALIGNMENT CONTROL	34
13.1	MICRO-SWITCH ADJUSTMENT.....	35
14	ELECTRICAL SYSTEM	36
14.1	CABLES AND MARKING.....	36
14.2	INSTALLATION, CONNECTION OF THE PIVOT PANEL.....	36
14.3	CONNECTION OF THE ALIGNMENT CONTROLS.....	37
15	INITIAL START-UP	37



15.1	CHECK-UP OF THE DIESEL PUMP GENERATOR SET	37
15.2	MAIN CART CHECK-UP	37
15.3	CHECK-UP OF TRUSSING, DRIVE TOWER AND OVERHANG	37
15.4	PIVOT PANEL	38
15.4.1	CHECK-UP OF VOLTAGE AND WIRING	38
15.5	ALIGNMENT OF THE TOWERS AFTER INSTALLATION	38
15.6	ADJUSTMENT OF ALIGNMENT CONTROL UNITS	39
15.7	ALIGNMENT CHECK-UP	40
15.7.1	CHECK OF TOWERS' TRAVELLING DIRECTION AFTER ALIGNMENT	41
16	TERMINOLOGY	41
17	START-UP	42
17.1	STARTING PROCEDURE WITH CONTROL PANEL SELECT PRO	42
17.1.1	START	42
17.1.2	START AFTER INTERMEDIATE STOP	43
17.1.3	SWIVELLING THE CENTERLINER CLX 9000	43
17.1.4	SWIVELING THE CLX MAIN CART	43
17.1.5	SHUT-DOWN PROCEDURE	45
17.2	ALIGNMENT OF THE SYSTEM	45
17.2.1	ALIGNMENT OF THE MAIN CART	45
17.2.2	ALIGNMENT OF THE BOOMS FOR LINEAR MODE	45
18	HOSE SUPPLY CLE / CLX	45
19	MAINTENANCE INSTRUCTIONS	47
19.1	SERVICE INTERVALS	47
20	SERVICE PLAN	48
20.1.1	POST-SEASON MAINTENANCE	49
20.1.2	PRE-SEASON MAINTENANCE	49
20.1.3	PRETENSIONING FORCES AND TIGHTENING VALUES OF BOLTS	50
21	TROUBLESHOOTING	51
21.1	RESTART AFTER DOGLEGGING WITH TOWER ALIGNMENT SWITCH	53
21.2	RESTART AFTER DOGLEGGING WITHOUT TOWER ALIGNMENT SWITCH	54
22	TECHNICAL DATA	55
22.1	DIMENSIONS OF CENTERLINER 9000	55
22.2	GEARBOX AND DRIVE MOTORS	56
22.2.1	GEARBOX	56
22.2.2	DRIVE MOTOR	56
23	OPTIONS	57
23.1	LOW PRESSURE SHUT-OFF	57
23.2	ELECTRIC SHUT-OFF VALVE (MAIN CART)	57
23.3	END GUN	57
23.4	BOOSTER PUMP FOR END GUN	57
23.5	AUTOMATIC "ON/OFF" CONTROL FOR THE END GUN / PUMP	57
23.6	AUTOMATIC INTERVAL CONTROL	57
23.7	AUTOMATIC „ON/OFF‘ AND INTERVAL CONTROL	57
23.8	DRIVE TOWER ALIGNMENT SWITCH	57
23.9	RUNNING LIGHT	57
23.10	END STOP	58
23.11	STOP RAMP	58
23.12	DOUBLE NOZZELING	58
23.13	REPOSITIONING OF CENTERLINER	58
23.13.1	TOWING THE CENTERLINER FROM THE MAIN CART	58
24	ELECTRIC CIRCUIT DIAGRAMS	61
24.1	CENTERLINER PIVOT PANELS	62
24.1.1	PIVOT PANEL SELECT PRO - IN-FEED	62
24.2	PIVOT PANEL SELECT PRO - CONNECTION DIAGRAM 1	68
24.3	CENTERLINER LINEAR CONTROL UNITS	74
24.3.1	CENTERLINER LINEAR CONTROL - FURROW GUIDANCE	74
24.3.2	CENTERLINER LINEAR CONTROL - CABLE GUIDANCE	75
24.3.3	CENTERLINER LINEAR CONTROL UNIT - BELOW GROUND GUIDANCE	76
24.4	ALIGNMENT CONTROL UNITS	80



24.4.1	ALIGNMENT CONTROL STANDARD.....	80
24.4.2	ALIGNMENT CONTROL WITH TOWER ALIGNMENT SWITCH.....	81
24.4.3	ALIGNMENT CONTROL WITH END TOWER MONITORING DEVICE	82
24.4.4	ALIGNMENT CONTROL WITH TOWER ALIGNMENT SWITCH AND END TOWER MONITORING DEVICE	83
24.4.5	ALIGNMENT CONTROL WITH TOWER ALIGNMENT SWITCH FOR ELECTRIC SWIVELLING OF THE DRIVE TOWER WHEELS.....	84
24.4.6	ALIGNMENT CONTROL WITH TOWER ALIGNMENT SWITCH AND END TOWER MONITORING DEVICE FOR ELECTRIC SWIVELLING OF DRIVE TOWER WHEELS.....	85
24.4.7	END CONTROL STANDARD	86
24.4.8	END CONTROL WITH TOWER ALIGNMENT SWITCH	87
24.4.9	END CONTROL WITH END STOP	88
24.4.10	END CONTROL WITH END STOP AND TOWER ALIGNMENT SWITCH.....	89
24.4.11	END CONTROL STANDARD WITH END STOP AND AUTOREVERSE.....	90
24.4.12	END CONTROL WITH DRIVE TOWER ALIGNMENT SWITCH WITH END STOP AND AUTOREVERSE.....	91
24.4.13	END CONTROL WITH DRIVE TOWER ALIGNMENT SWITCH FOR ELECTRIC SWIVELLING OF THE DRIVE TOWER WHEELS.....	92
24.5	BOOSTER PUMP FOR END GUN	93
25	SERVICE PROOF.....	94
26	CONFORMITY CERTIFICATE	98



1 GENERAL INSTRUCTIONS

CE SYMBOL



The **CE symbol** that has to be affixed on the machine by the manufacturer outwardly demonstrates compliance of the machine with the directives for machines and other relevant EC directives.

CE conformity certificate (see Annex)



WARNING !

This “**Warning**” symbol refers to important safety instructions in this manual. Whenever you see this symbol be aware of possible injury hazards. Read the note following the symbol very carefully and inform the other operators accordingly.



CAUTION !

Non-observance of this instruction may damage or destroy the machine or individual components.

NOTE!

It is very important to observe this note or instruction carefully!

Qualified operators

These are persons who on behalf of their training, experience and instruction as well as their knowledge of relevant standards, rules, precautions to be taken for accident prevention, and prevailing operating conditions, have been authorised by the person in charge of plant safety to perform the respective tasks required, and in doing so are able to recognise and avoid potential hazards. Among other things, knowledge of first-aid procedures is also required.

Warranty terms

The currently applicable warranty terms are indicated in detail on the Sales Contract with Bauer company. In general the warranty period is 12 months after start-up.

Duty to furnish information

Even if he passes on the machine to a new owner later-on, the customer is obliged to hand on the operating manual to the new owner, too. The receiver of the machine must be instructed with reference to the mentioned regulations.

Intended use

- BAUER CENTERLINER CLX 9000 has been constructed exclusively for use in normal irrigation (*intended use*).
- Any employment beyond this normal use is considered non-conforming. The manufacturer is not liable for damage resulting from such non-conforming use, the sole liability for damage from non-conforming use is with the user.
- Intended use also includes compliance with manufacturer’s operating, maintenance and service instructions.
- BAUER CENTERLINER CLX 9000 may be used and operated only by persons who are familiar with the system and aware of the hazards involved.
- All relevant rules for accident prevention as well as any other generally accepted specifications and regulations relating to safety, work medicine and traffic law must be strictly observed.
- Unauthorised modifications on the machine release the manufacturer from liability for damage resulting therefrom.

2 WARNING SYMBOLS

Danger points on the pivot system are specifically marked by safety stickers. These stickers must be affixed at the mentioned points clearly visible and serve for protection of persons working on or near the system.

1.  **WARNING !**

Study and observe the manual and all safety instruction carefully before you put the system into operation.

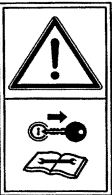
2.  **WARNING !**

Before maintenance and repair work, always stop the system, disconnect all power, and read the operating manual.

3.  **WARNING !**

1. This system is powered by 400 Volts!
Danger of electrical shock / injury hazard !
2. Do not attempt to check any components while the system is live!
3. Open the inner pivot panel door only when main disconnect is OFF.

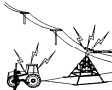
4.  **WARNING !** 

1. The working range of the CENTERLINER must always be at a safe distance from electrical power lines.
2. Pull towable systems only at a safe distance from electrical power lines.
Make sure that the water jet from spray nozzles and end gun does not hit electrical lines.

5.  **WARNING !**

The system can start automatically. Always keep a safe distance from the towers.

6.

**WARNING !**

1. Do not remove shaft guards.
2. When repair work is performed on the system, make sure that system cannot start running automatically. Disconnect the complete system from power.

3 GENERAL HINTS

BAUER CENTERLINER CLX 9000 is an irrigation system consisting of a main cart and boom elements (*spans*). The CENTERLINER is apt for rectangular or circle irrigation or a combination thereof.

Different irrigation functions can be performed manually or fully automatic. The BAUER CENTERLINER CLX 9000 is available as non-towable or towable system.

Via hydrants and a flexible connection hose, the systems are supplied with water. The four-wheel main cart is equipped with a Diesel generator unit, which supplies the power for the drive of the system; also mounted on the main cart is the control panel.

The main cart and the boom elements (towers, spans) are driven electrically. The joints (tower couplings) mounted between the spans allow horizontal and vertical angular deviation between the individual boom elements so that the system can adjust perfectly to the existing site conditions.

Electric alignment controls between the spans control the horizontal angular deviation and ensure that the system runs in a straight line.

Through varying spray nozzle set-ups and system speeds it is possible to tailor the water application exactly to all possible plant and soil requirements.

The travel direction of the system is determined by a furrow drawn in the soil (*furrow guidance*), by a stretched cable (*cable guidance*) or by a below ground cable (*below ground guidance*).

4 GENERAL INSTRUCTIONS FOR SAFETY AND ACCIDENT PREVENTION

Check the operational safety of the machine before every start.

1. In addition to the instructions in this manual, be sure to observe all specifications generally valid for safety and accident prevention!
2. The warning signs and notes affixed to the machine contain information essential to safe operation. Observing them serves your own personal safety!
3. Do not start the machine unless all guards and safety devices are mounted completely and in proper working position!
4. Acquaint yourself with all system components and controls as well as their respective functions, before you start to work. It is too late for this when the system is already running!
5. Check the vicinity of the system before start-up (*children!*). Make sure that sight is unobstructed!
6. For towing, couple the device according to the instructions and fix it only at the prescribed devices!

Electrical system check-up

1. Before the first start-up, check the electrical system and ensure that the installation complies with the safety requirements.
2. Check the electrical system visually before every start-up.
3. All work beyond normal maintenance of the system is to be performed by a qualified service person only!
4. Never repair or service any part of the before all power has been disconnected!



Maintenance

- As a rule, maintenance and cleaning work as well as repairs of malfunctions may be done only with the drive and the motor turned off!
- Check proper seat of nuts and screws regularly, and tighten them, if needed!
- Dispose of oil, grease, and filters in accordance with regulations.
- Always disconnect system from power before starting any work on the electrical system!
- Before electrical welding on the system itself or built-on components, disconnect the mains or generator supply cable!
- Spare parts must meet minimum technical requirements by the manufacturer of the device.! This is guaranteed by original equipment parts!

5 SAFETY PRECAUTIONS FOR CENTERLINER CLX 9000

In addition to the GENERAL INSTRUCTIONS FOR SAFETY AND ACCIDENT PREVENTION, the following safety principles must be observed for operating BAUER – CENTERLINER CLX 9000.

ELECTRICAL SYSTEM



WARNING !

Since the system is powered by 400 V, always practice extreme caution when dealing with the electrical system and the electric drive !

1. All metal parts of the unit must be interconnected, all tower couplings must be bridged with a cable.
2. In addition the yellow-green marked protective conductor, which goes with the power supply, must be connected to the protective conductor clamp in the control panel.
3. Before working on system electrical components, make sure the system is disconnected from all poles and sources, and that generating unit is stopped..
4. Provide a lock-out at the main disconnect to protect yourself against unintentional reclosing.
5. Verify safe isolation of electrical system.
6. Never repair or short-circuit a fuse by means of a wire or any other item.
7. Immediately repair or replace all wires with defective isolation.
8. Short-circuiting of system safety circuit is to be done only by a qualified person and only for the purpose of realigning the system.

MECHANICAL SYSTEM



WARNING !

1. Never service or repair any part or system component while the plant is operating.
2. Always disconnect the system from power before starting any maintenance work. Turn the main disconnect to „O“ and lock the switch to prevent unintentional reclosing and stop the generating unit. This disconnection needs to be done manually !
3. Before you start, make sure that all persons have left the operating range of the system.
4. Make sure that no objects or vehicles are in or near the system tracks when system is running/starting to operate.
5. When the system is operating, the towers come on and off automatically. Keep a safe distance from the towers.
6. Never step on the system while it is running.
7. Utmost care is required by the operator when spans are aligned.
8. Always turn off the system and water supply before working on sprinklers or spray nozzles.
9. Use adequate means of access (*ladder, elevating platform*) for work on sprinklers or spray nozzles.
10. Proceed with the utmost caution, when system is working near or under electric power lines, so that neither the metal structure nor the water jets of sprinklers get in contact with live wires.
11. When towing movable systems, make sure that the system does not get in contact with a power line.
12. Make sure that not neighbouring plots or roads are wetted by the end gun. This could cause damage or accidents.
13. If fertilisers or other chemicals are added to the irrigation water, avoid mist and do not inhale it.

6 TECHNICAL DESCRIPTION

6.1 CENTERLINER OPERATING MODES

The **CLX** design irrigates rectangular fields in linear mode. At the field end the system automatically can swing around the main cart inward (*without irrigation*) or outward (*optional with irrigation*) to the opposite side of the field and continue irrigation automatically.

6.1.1 LINEAR MODE

LINEAR

Linear mode - Start forward / reverse
Operation with water until intermediate stop / final stop

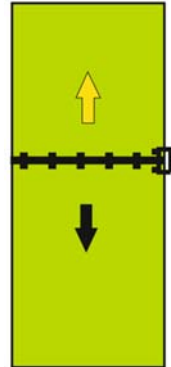

6.1.2 PIVOT MODE

PIVOTING

Pivot mode with adjustable irrigation angle.

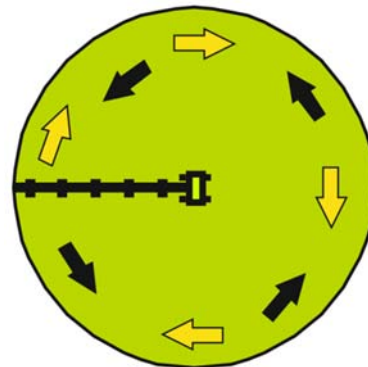

6.1.3 AUTOMATIC INWARD SWIVELLING MODE

INSWING
CONTINUE OFF

- Linear mode with water
- 180° inward swivelling in dry mode at Vmax
- Stop
- Then possibility to continue in **LINEAR MODE**.
Not necessary to re-couple feeding hose.

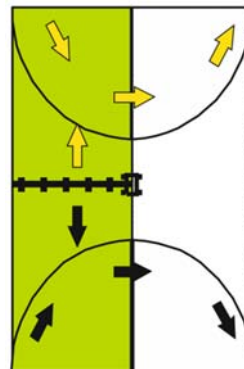

6.1.4 AUTOMATIC OUTWARD SWIVELLING MODE

OUTSWING
CONTINUE OFF

- Linear mode with water
- 180° outward swivelling with irrigation
- Stop
- Then possibility to continue in **LINEAR MODE**.
Not necessary to re-couple feeding hose.

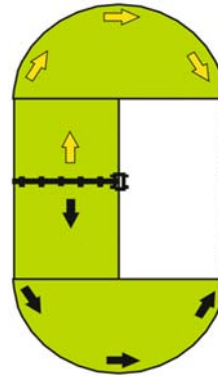

6.1.5 AUTOMATIC INWARD SWIVELLING MODE AND AUTOMATIC CONTINUED TRAVEL IN LINEAR MODE

INSWING
CONTINUE ON

- Linear mode with water
- 180° inward swivelling with irrigation
- Stop
- *Automatic continued travel* in **LINEAR MODE**
Not necessary to re-couple feeding hose.

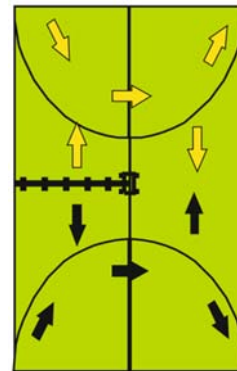

6.1.6 AUTOMATIC OUTWARD SWIVELLING MODE AND AUTOMATIC CONTINUED TRAVEL IN LINEAR MODE

OUTSWING
CONTINUE ON

- Linear mode with water
- 180° outward swivelling with irrigation
- Stop
- *Automatic continued travel* in **LINEAR MODE**
Not necessary to re-couple feeding hose.

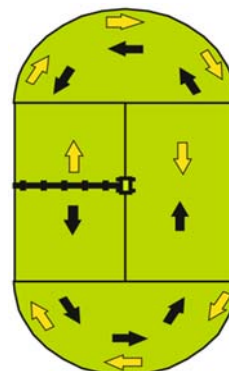

6.1.7 AUTOMATIC OUTWARD / INWARD SWIVELLING MODE

INSWING **CONTINUE OFF**

- Linear mode with water
- 90° (or any angle) inward swivelling in dry mode with Vmax
- Stop
- Manual swivelling of the central unit by 90° (or any angle)
- Then possibility to continue in **LINEAR MODE**.

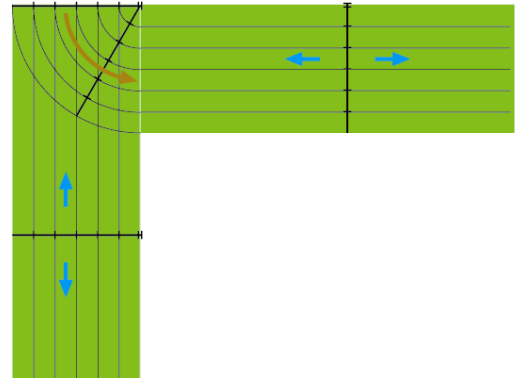

OUTSWING **CONTINUE OFF**

- Linear mode with water
- 90° (or any angle) outward swivelling with irrigation
- Stop
- Manual swivelling of the central unit by 90° (or any angle)
- Then possibility to continue in **LINEAR MODE**.

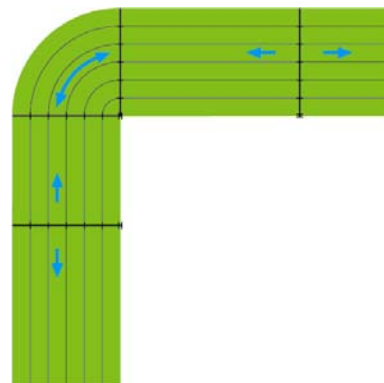

6.2 COMPONENTS OF THE CENTERLINER

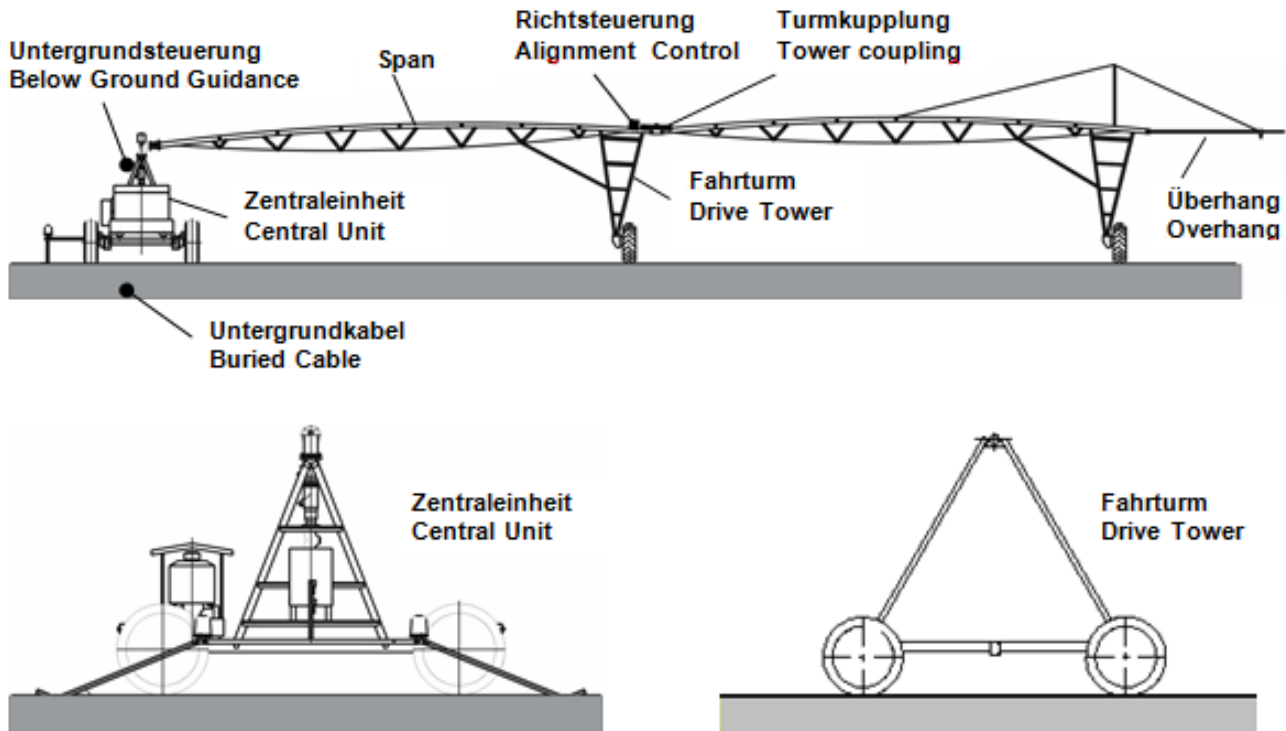

MAIN CART (central unit)

Travelling main cart (tires depending on design fixed or swivable) with linear control, diesel generator unit, connection for water supply, control panel, electro-mechanical control device for linear and pivot mode.

SPAN

Arched truss consisting of the water-carrying pipes, the truss rods and V-Jack.

DRIVE TOWER

Carries the span weight and provides the electromechanical drive of the system. Consists of wheel carrier, tower bracing angle, electrical drive motor, drive shafts, wheel gear and wheels.

TOWER COUPLING

Joint between the spans. Possible articulation: up to 30%.

ALIGNMENT CONTROL

Electromechanical control system, that monitors the horizontal angular deviation between the spans and switches the drive motors.

OVERHANG

Overhanging part from last tower to system end.

END GUN

Wide range sprinkler at the end of overhang for more spraying range

BOOSTER PUMP

Electric pump on the last tower for increase of pressure to end gun

BELOW GROUND GUIDANCE

The components of the below ground guidance receive signals emitted by a below ground cable, which are evaluated and are made available to the linear guidance of the CENTERLINER with BELOW GROUND GUIDANCE.

BELOW GROUND CABLE

Signals for linear guidance of the machine are emitted via the below ground cable.

6.2.1 COMPONENTS OF THE BELOW GROUND GUIDANCE

6.2.1.1 OSCILLATOR BOX ASSEMBLY

OSCILLATOR BOX

The oscillator box generates the signal required for the linear guidance which is fed to a conductor loop (*below ground cable*).

COVER

The cover serves to protect the unit against weather influences such as rain, wind, sun etc.

MOUNTING LEGS

The oscillator box and cover are mounted to the two mounting legs. Both mounting legs are plugged into the soil directly at the end of the field.

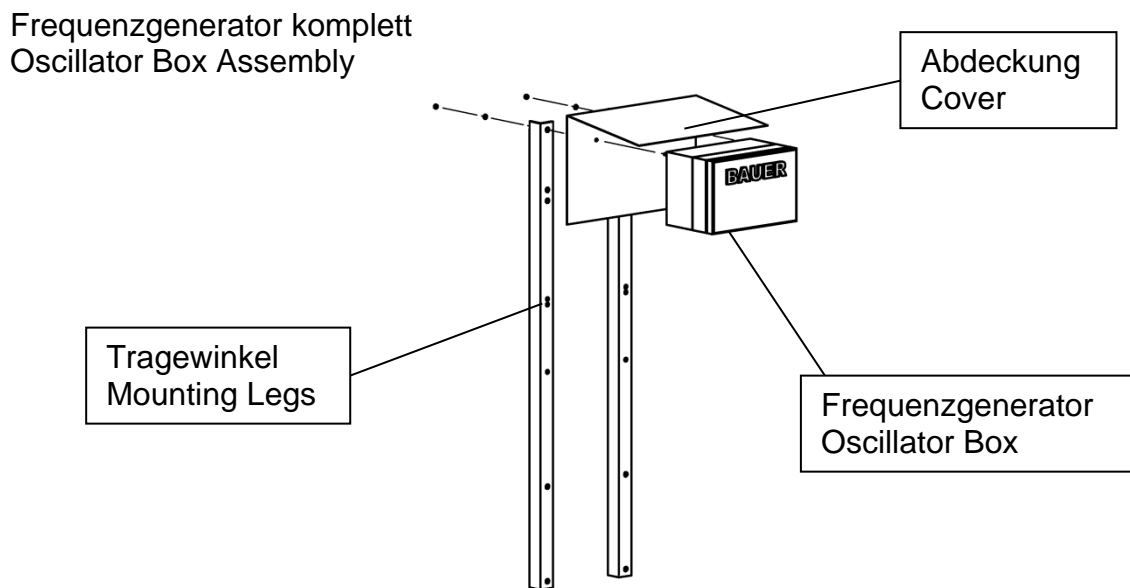

6.2.1.2 STEERING ANTENNAS

The steering antennas are mounted to the antenna mounting devices. They receive the signal emitted by the underground cable.

6.2.1.3 TRACK UNIT

The signal received by the steering antenna is processed in the track unit and is transmitted to the control centre.

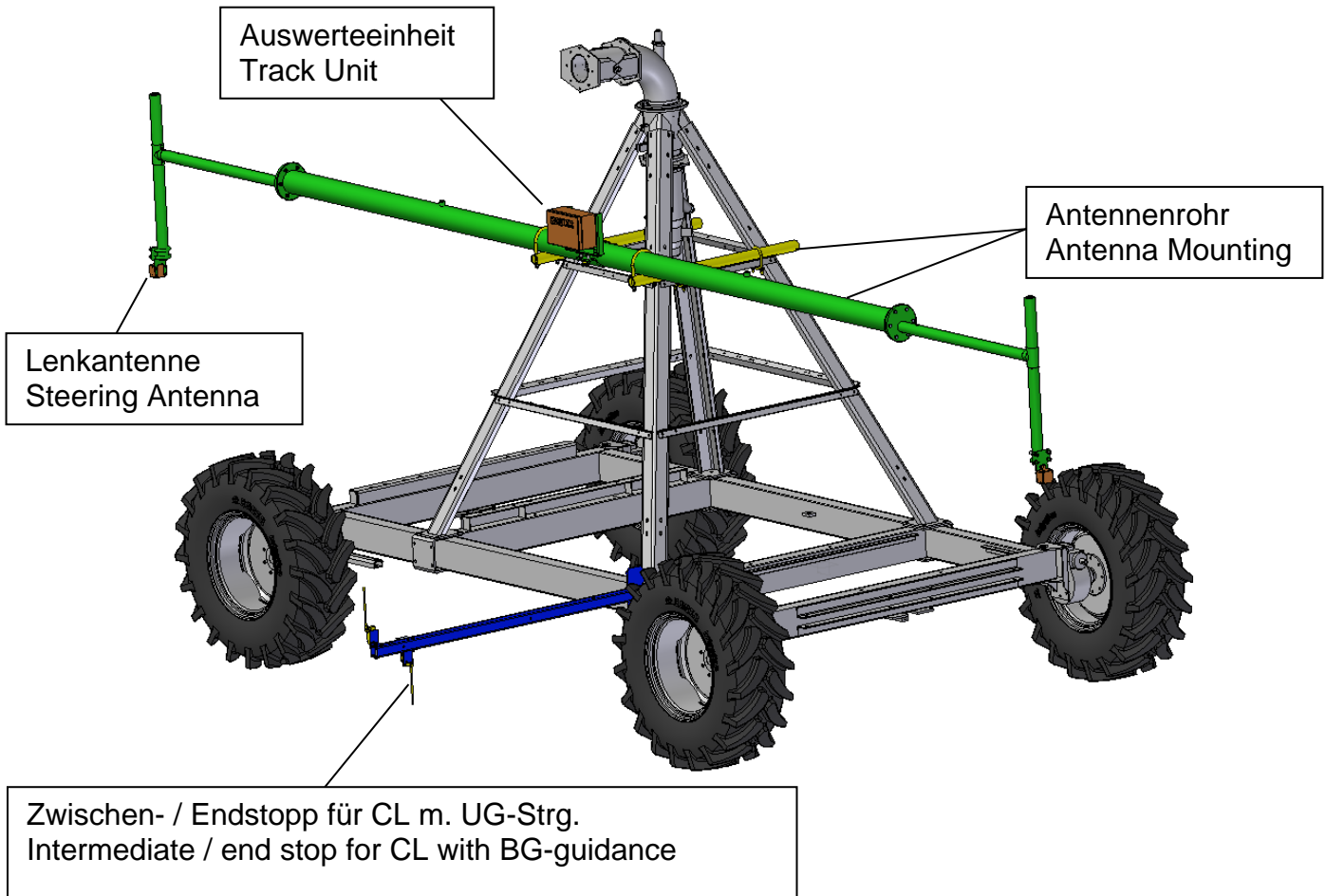

7 USE OF CENTERLINER

7.1 PERMISSIBLE BENDING ANGLES

7.1.1 HORIZONTAL

Sicherheitssystem abgeschaltet / Safety system shut off

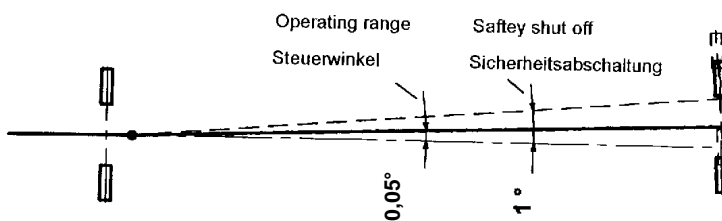

The working angle between the individual spans is $\pm 0,15^\circ$.

When exceeding this angle (e.g. due to rough ground), the safety system (safety circuit) shuts off the CENTERLINER when 1° is reached (default setting).

The working range of the first span at the main cart is $\pm 0,4^\circ$ of the set 90° (towards the main cart). The safety circuit is activated at 1° (default setting).

7.1.2 INCLINATION

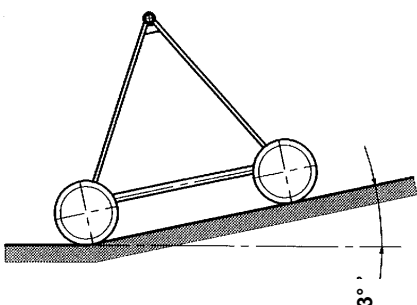

The maximum permissible inclination along the travel direction in linear mode for the main cart as well as for the towers is $3,0^\circ$.

7.1.3 INCLINATION, VERTICAL ANGULAR DEVIATION

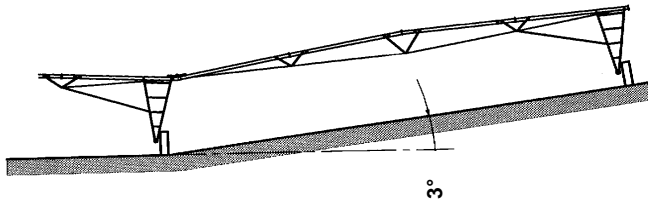

Maximum permissible inclination along the span is 3,0°.

Maximum difference in elevation between main cart and the first tower is 1 m !

7.2 TRACK DETERMINATION AND MAINTENANCE

The determination of the track is extremely important, because it has an essential influence on the control of the system.

- Track depth: max. 140 mm
- Track depth with swivel able systems in rotating range: max. 100 mm
- Track of main cart: completely plain and free of grooves

7.2.1 TRAVELLING DIRECTION

Before cultivating the crop resp. preparing the seed bed the following needs to be considered:

- Standard operation of the system is vertical to the crop rows.
- If the seed bed depth is more than 100 mm, an operation of the system parallel to the crop rows is recommended.

If it is required to operate the system parallel to the crop rows, apply one of the following methods to determine the track.

Method I

1. Before cultivating run „dry“ along the entire field. That way the tracks are determined.
2. Use these tracks as guidance for the crop row to be cultivated.
The distance of the first crop rows to the left and the right of the track shall be 250 mm.

Method II

1. Plant the entire field parallel to the system's travel direction.
2. Run „dry“ along the entire field.
3. Level out the crop rows 250 mm to the left and the right of the tracks. That way deep tracks and cracks between the crop rows can be prevented.
An exact run of the system is guaranteed.

Instructions for determining tracks

1. Run once "dry" at maximum speed over the entire field.
2. A second time run "wet" with ca. 5 mm precipitation (*at 80 - 90 % of maximum speed*) over the entire field.

Subsequent operation of the system as desired.

If the tracks become too deep, they need to be levelled out or filled up. Then run the system dry at maximum speed over the entire field. The reverse run „wet“ at maximum speed , i.e. 1 mm precipitation.

8 CENTERLINER MAIN CART

8.1 MAIN CART CLX / CLX-T

The main cart CLX-T is towable.

The main cart consists of the following components:

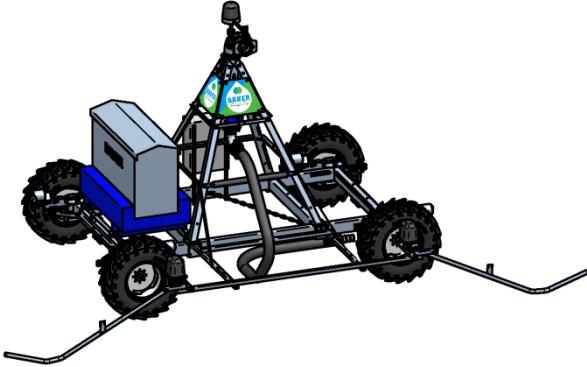

- Main frame with 4 swivelable wheels (14.9-24), electrically swivelable with control cartridge, wheels with disengageable transmission on CLX -T.
- 4 drive gear motors 0,55kW, mounted centre tower for swivelable boom.
- Central system supply with flexible hose piece, no switching of the supply hose at the end of the field required.
- Connection rising pipe DN150(200), electrical shut-off valve (*option*),
- Control panel SELECT PRO,
- Linear guidance (*furrow guidance, cable guidance or below ground guidance*). *induction guidance*)
- Positional control with absolute encoder,
- Diesel generator unit depending on system requirement 10kVA – 20kVA,
- Connecting hose depending on system capacity 3 1/2"-5"

The swivelling of the boom can be done automatically in operating mode *INSWING* or *OUTSWING*. Irrigation while swivelling is possible on demand.

With the CLX-T design the wheels of the main cart can be swivelled electrically for the towing process. At the field end it is not necessary to re-couple the connection hose for the reverse run.

9 CONTROL PANEL

9.1 CONTROL PANEL SELECT PRO FOR CENTERLINER CLX

Design and material according to ÖVE and VDE norms, the built-in components correspond to the IEC norms and the VDE regulations.



- Waterproof polyester box (*protection class IP 54*) with lockable front door, swivel mounted panel. Can only be opened when main switch is turned off.
- Operating voltage of system : 400 V
- Control voltage : 230 V single phase
- Isolating transformer for control voltage
- Industrial control gear usual in trade
- Cable connections with cable shoes
- Protective device



WARNING !

Keep control unit always locked during operation in order to prevent impurity and splash water

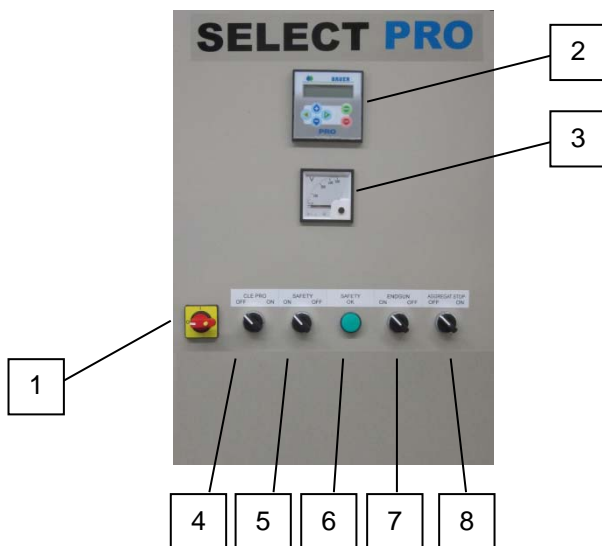

1. Main switch
2. Control panel SELECT PRO
3. Hourmeter
4. Switch "CLE PRO OFF - ON"
5. Switch safety circuit "ON – OFF"
6. Luminous button „safety circuit“
7. Switch „END GUN ON - OFF“
8. Switch "GENERATOR STOP OFF – ON"
9. Switch "EMERGENCY STOP" (*not shown on the picture*)



9.1.1 STANDARD BUILT-IN COMPONENTS

9.1.1.1 MAIN DISCONNECT

The main switch turns off or on the entire power supply.

In position „I“ the electrical supply is established

In this position the swivel mounted panel is locked due to safety reasons.

In position „0“ the electrical supply of the system is cut off.

In this position the main switch can be locked in order to prevent an accidental or unintended turning on.

Only in this position the swivel mounted panel can be opened.

9.1.1.2 CONTROL PANEL SELECT PRO

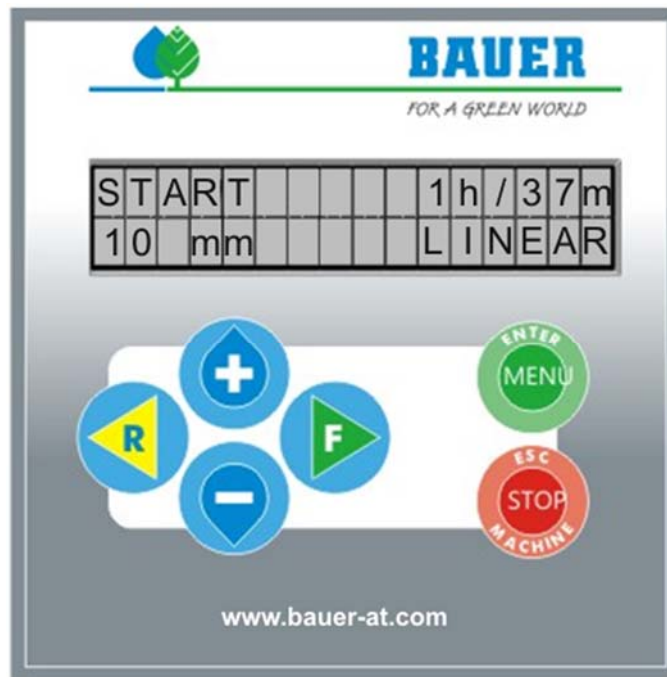

9.1.1.2.1 DISPLAY

Display with 2x16 signs, 2 lines, background lighting. If you do not use the keypad for a predetermined time, the background lighting switches off automatically (*timer for background lighting adjustable*).

9.1.1.2.2 FUNCTION / MENU BUTTONS

- | | |
|-------------------------------|--|
| START FORWARD (F) | Start the <i>CENTERLINER</i> moving forward (<i>clockwise</i>) |
| START REVERSE (R) | Start the <i>CENTERLINER</i> moving backward (<i>counter-clockwise</i>) |
| MENU and ENTER | Pressing this button loads the user level –
Double use for entering the programming mode of a parameter as well as for confirming an input. |
| STOP (ESC and machine) | Stops operation; this button is also used to enter the expert mode and for saving and leaving the programming mode. |

- +** With this button, you can change the irrigation amounts for the current direction of travel during operation; it is also used to modify parameters.

- With this button, you can change the irrigation amounts for the current direction of travel during operation; it is also used to modify parameters.

WARNING: A detailed functional description of the *operating panel SELECT PRO* can be found in the separate operating manual.

9.1.1.3 VOLTMETER

Indicates the voltage between phases L1 and L2.

9.1.1.4 SWITCH "CLE PRO OFF - ON"

In position "ON", the *CENTERLINER* can be started with the control panel. Putting the switch to position "OFF", shuts off the entire operating system of the machine.

9.1.1.5 SWITCH "SAFETY CIRCUIT ON - OFF"

When turned "ON", malfunction (e.g. doglegging) will shut off the entire system. The "OFF" position serves exclusively for system alignment by a qualified operator. **This switch MUST always be turned to "ON" while system is operating!!** This is the only way to guarantee safety when system is operating unattended.

9.1.1.6 LUMINOUS BUTTON "SAFETY CIRCUIT"

Is lit when the "SAFETY CIRCUIT ON – OFF" switch is in "OFF" position.
Is lit when the "SAFETY CIRCUIT ON – OFF" switch is in "ON" position and the machine is not in the safety circuit.

9.1.1.7 SWITCH "END GUN ON - OFF"

In "OFF" position, the end gun is out of operation and in "ON" position the end gun is in operation.

9.1.1.8 SWITCH "GENERATOR STOP OFF – ON"

The generator group switch off automatically.

- ON When the system runs into the safety circuit.
- At a pressure drop in the supply line .
 - At the end stop
 - At an intermediate stop, e.g. to change the connection of the supply hose.
 - Use this setting during a regular run !
- OFF In this position the generator unit does not switch off in the cases mentioned above. This setting is used
- When aligning the towers.
 - When operating the system without water.

9.1.1.9 "EMERGENCY STOP" BUTTON

This switch serves to interrupt the voltage supply to the control unit (*not shown on the picture*).



9.2 CONTROL PANEL SELECT PRO-G FOR CENTERLINER CLX

Design and material according to ÖVE and VDE norms, the built-in components correspond to the IEC norms and the VDE regulations.



- Waterproof polyester box (*protection class IP 54*) with lockable front door, swivel mounted panel. Can only be opened when main switch is turned off.
- Operating voltage of system : 400 V
- Control voltage : 230 V single phase
- Isolating transformer for control voltage
- Industrial control gear usual in trade
- Cable connections with cable shoes
- Protective device

WARNING ! Keep control unit always locked during operation in order to prevent impurity and splash water

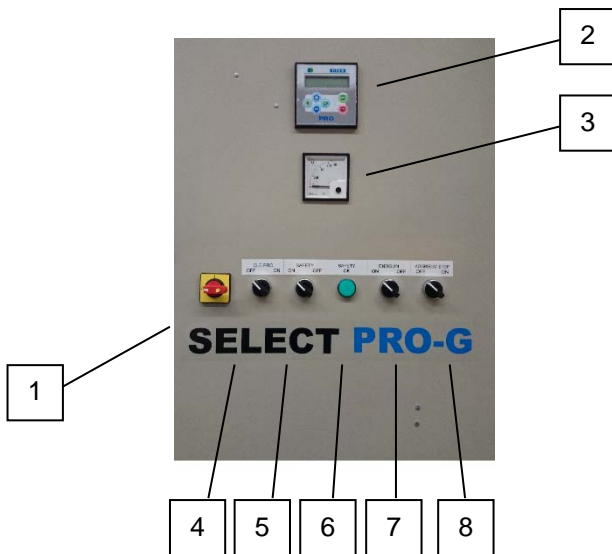

1. Main switch
2. Control panel SELECT PRO-G
3. Hourmeter
4. Switch "CLE PRO OFF - ON"
5. Switch safety circuit "ON – OFF"
6. Luminous button „safety circuit"
7. Switch „END GUN ON - OFF"
8. Switch "GENERATOR STOP OFF - ON"
9. Switch "EMERGENCY STOP" (*not shown on the picture*)
10. GPS unit (*not shown on the picture*)

9.2.1 STANDARD BUILT-IN COMPONENTS

9.2.1.1 MAIN DISCONNECT

The main switch turns off or on the entire power supply.

In position „I“ the electrical supply is established

In this position the swivel mounted panel is locked due to safety reasons.

In position „0“ the electrical supply of the system is cut off.

In this position the main switch can be locked in order to prevent an accidental or unintended turning on.

Only in this position the swivel mounted panel can be opened.

9.2.1.2 CONTROL PANEL SELECT PRO-G

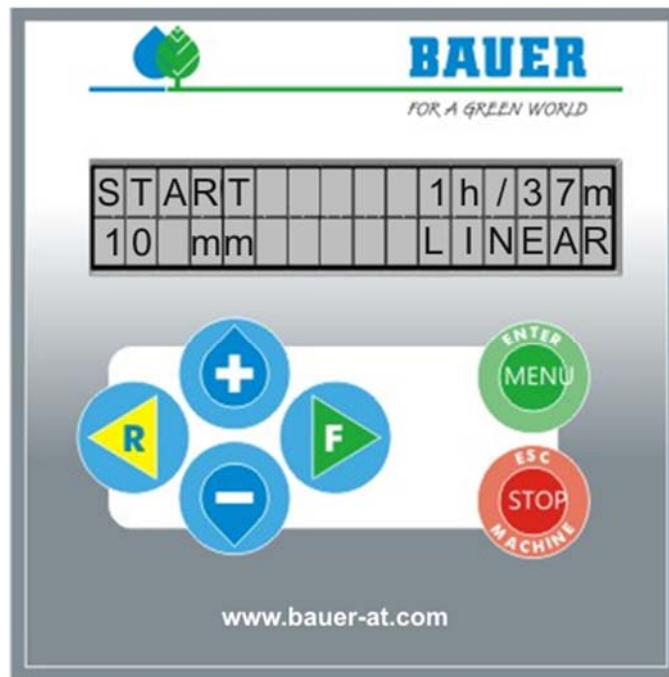

9.2.1.2.1 DISPLAY

Display with 2x16 signs, 2 lines, background lighting. If you do not use the keypad for a predetermined time, the background lighting switches off automatically (*timer for background lighting adjustable*).

9.2.1.2.2 FUNCTION / MENU BUTTONS

- | | |
|-------------------------------|--|
| START FORWARD (F) | Start the <i>CENTERLINER</i> moving forward (<i>clockwise</i>) |
| START REVERSE (R) | Start the <i>CENTERLINER</i> moving backward (<i>counter-clockwise</i>) |
| MENU and ENTER | Pressing this button loads the user level –
Double use for entering the programming mode of a parameter as well as for confirming an input. |
| STOP (ESC and machine) | Stops operation; this button is also used to enter the expert mode and for saving and leaving the programming mode. |

- +** With this button, you can change the irrigation amounts for the current direction of travel during operation; it is also used to modify parameters.



- With this button, you can change the irrigation amounts for the current direction of travel during operation; it is also used to modify parameters.

WARNING: A detailed functional description of the *operating panel SELECT PRO* can be found in the separate operating manual.

9.2.1.3 VOLTMETER

Indicates the voltage between phases L1 and L2.

9.2.1.4 SWITCH "CLE PRO OFF - ON"

In position "ON", the *CENTERLINER* can be started with the control panel. Putting the switch to position "OFF", shuts off the entire operating system of the machine.

9.2.1.5 SWITCH "SAFETY CIRCUIT ON - OFF"

When turned "ON", malfunction (e.g. doglegging) will shut off the entire system. The "OFF" position serves exclusively for system alignment by a qualified operator. **This switch MUST always be turned to "ON" while system is operating!!** This is the only way to guarantee safety when system is operating unattended.

9.2.1.6 LUMINOUS BUTTON "SAFETY CIRCUIT"

Is lit when the "SAFETY CIRCUIT ON – OFF" switch is in "OFF" position.
Is lit when the "SAFETY CIRCUIT ON – OFF" switch is in "ON" position and the machine is not in the safety circuit.

9.2.1.7 SWITCH "END GUN ON - OFF"

In "OFF" position, the end gun is out of operation and in "ON" position the end gun is in operation.

9.2.1.8 SWITCH "GENERATOR STOP OFF – ON"

The generator group switch off automatically.

- ON When the system runs into the safety circuit.
- At a pressure drop in the supply line.
 - At the end stop
 - At an intermediate stop, e.g. to change the connection of the supply hose.
 - Use this setting during a regular run!
- OFF In this position the generator unit does not switch off in the cases mentioned above. This setting is used
- When aligning the towers.
 - When operating the system without water.

9.2.1.9 "EMERGENCY STOP" BUTTON

This switch serves to interrupt the voltage supply to the control unit (*not shown on the picture*).

9.2.1.10 GPS UNIT

GPS unit for absolute position recognition, mounted at the main cart (*not shown on the picture*).

10 LINEAR CONTROL SYSTEM

In linear operation, the CENTERLINER is guided along a furrow in the soil (*furrow guidance*), along a guiding cable (cable guidance) or contactless along a cable laid below ground (induction guidance).

The linear control system mounted laterally to the main cart, controls the wheel pairs of the main cart.

This control system keeps the system always at the same distance and at right angles to either the guiding furrow, to the guiding cable or to the below ground cable.

The distance and the angle of the main cart to the guiding furrow and/or to the guiding cable is transmitted to the correction control unit by means of two control rolls and/or skids. For the inductive guidance, the guiding signal of the below ground cable is caught by the steering antennas and subsequently transmitted to the control centre.

The linear control system (*furrow, cable*) consists of two control units whereby the front unit (*seen in travel direction*) always controls the system and the electric drive motors of the main cart.

For emitting the guiding signal (*INDUCTION GUIDANCE*) an additional oscillator box is necessary (*not for furrow- and cable guidance*).

10.1 FURROW GUIDANCE

Max. deviation from the straight line

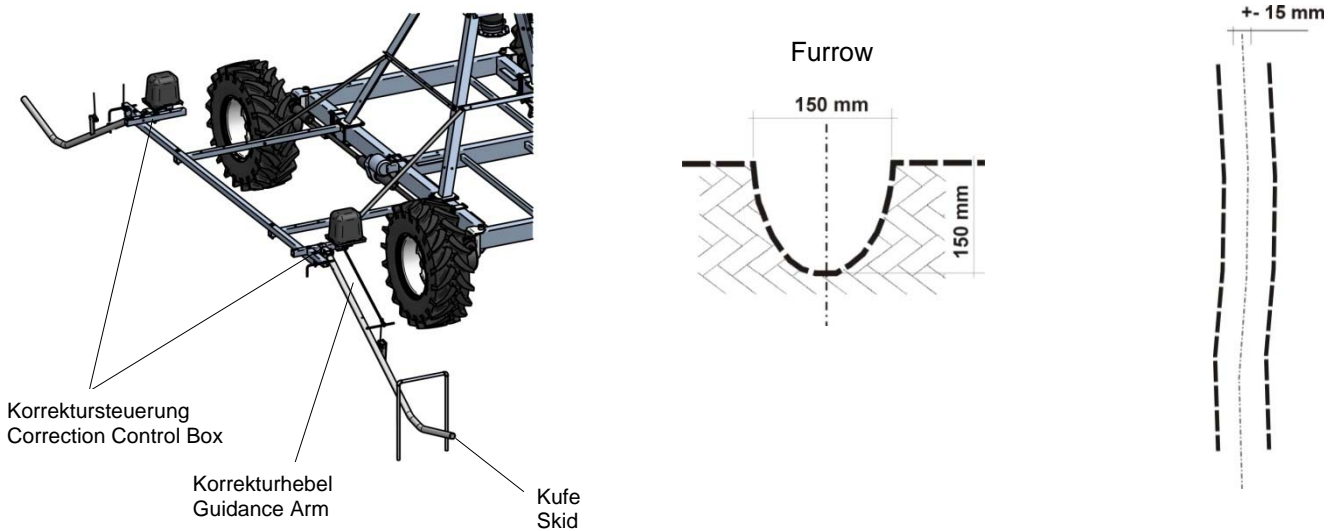

Admissible curve radius of the guide furrow

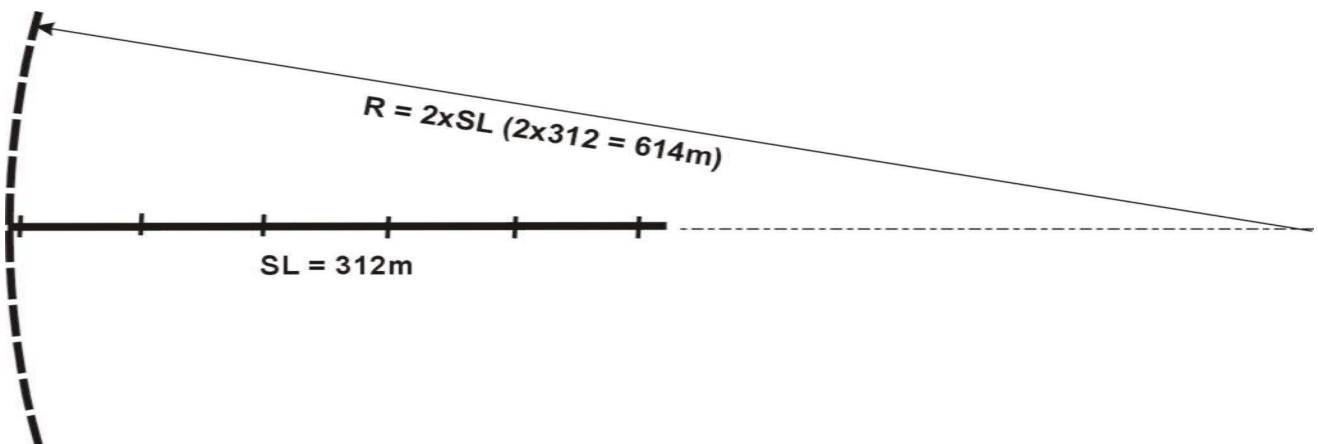

SL.... System length of the Centerliner
 RRadius of the admissible curve

10.2 CABLE GUIDANCE – ASSEMBLY AND SETTING

1. The cable guidance system consists of a cable stretched 0,6 m above ground which is carried by cable holders arranged at a distance of 6 m. For assembly, mind the following 2 items:

- The cable holders must be aligned exactly.
- The cable must be tensed duly.

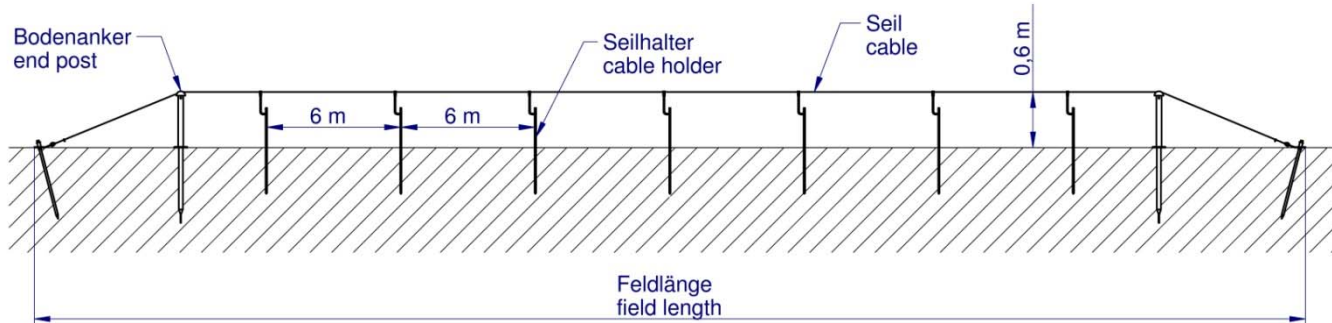

2. Cable holder: The cable holders must be arranged in parallel to the channel (*channel feeding*) and/or in parallel to the track of the main cart (*hose feeding*).

The cable holders must be in exact alignment. The distance between the cable holders is 6 m. The end posts at the field ends must be fixed steadily by means of ground anchors in order to take up the cable tension.



3. Cable

The cable is fixed to the cable holders by means of clips welded to the cable holders.

On the end post, the cable end is fixed with grummet thimble and with three cable clamps. 5 m before the cable end, a second cable of 10 m is fixed with 3 cable clamps. The end of this cable is fixed to a vehicle or a tractor and it is stretched until reaching the required cable tension. The cable tension shall be ca. 4000 N. Once the cable has been tensioned correctly, the main cable will be fixed to the end post and the second cable will be removed.

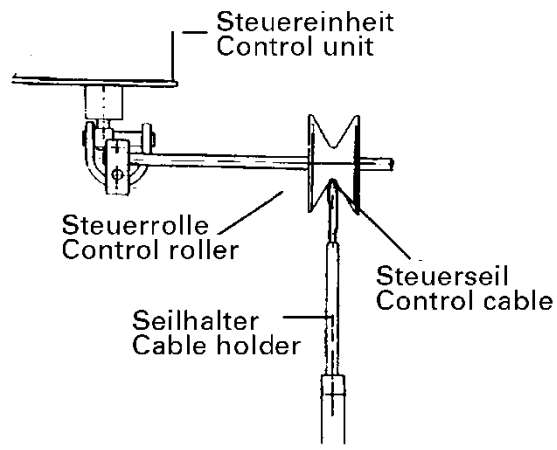
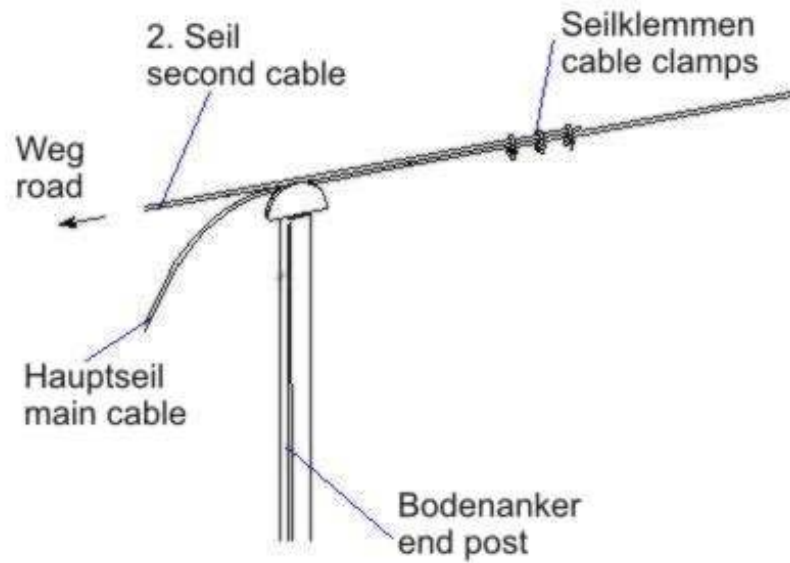



10.3 BELOW GROUND GUIDANCE

10.3.1 OSCILLATOR BOX, STEERING ANTENNAS, TRACK UNIT

The **oscillator box assembly** is supplied in a hose-proof box with a steel sheet cover and it is set up on the corresponding mounting legs directly on the field anywhere along the conductor loop. It is purposeful not to set it up on the irrigated / planted surface.

Frequenzgenerator komplett
Oscillator Box Assembly

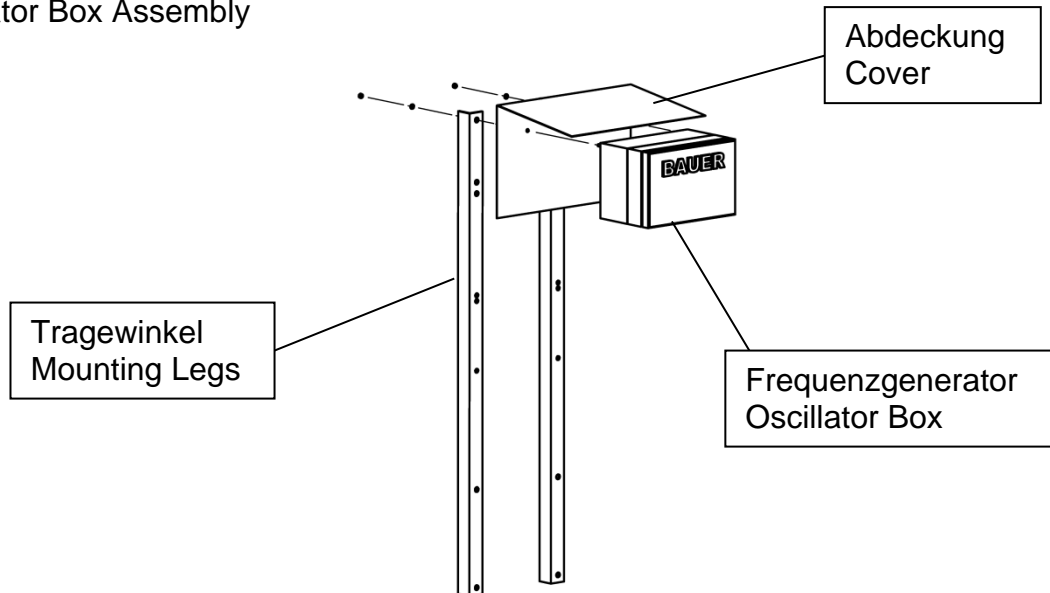

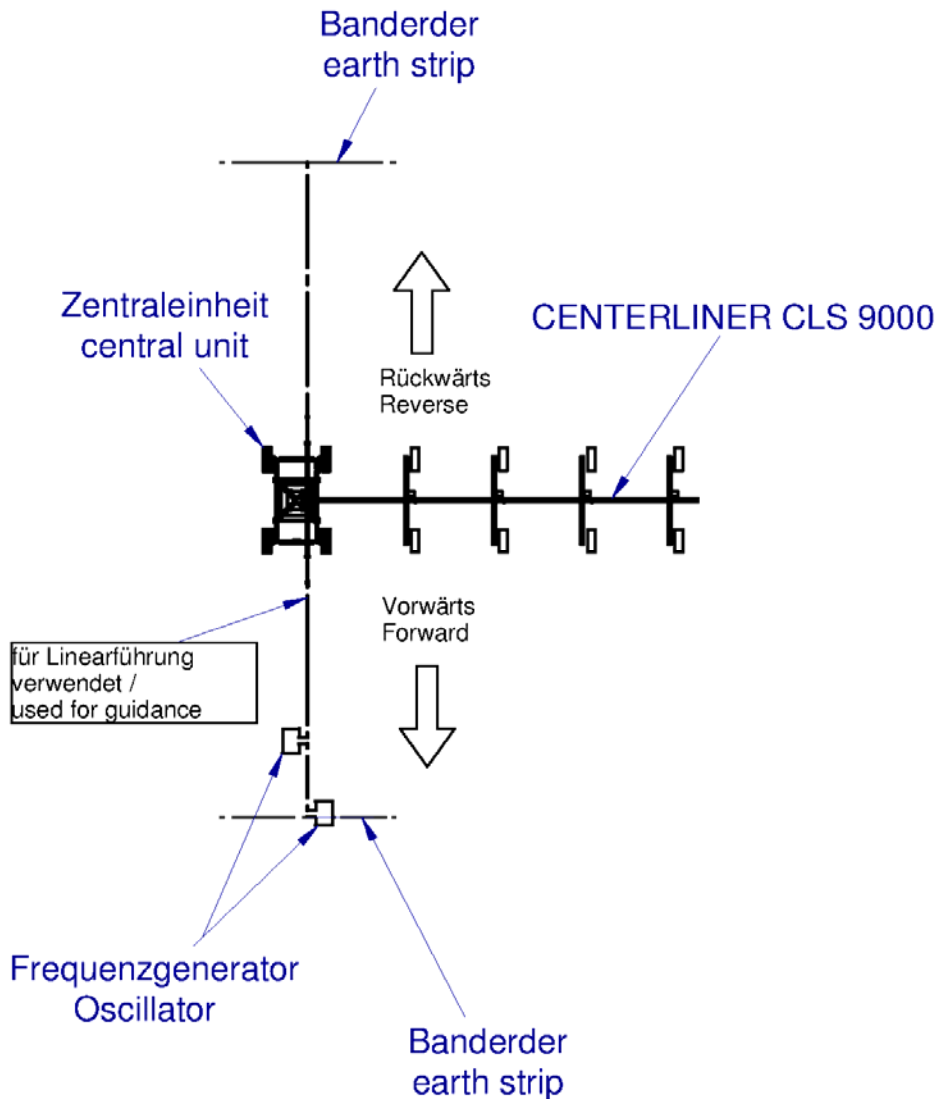

By means of the transformer installed, the oscillator box can either be connected to a 230V AC / 50Hz supply line or it can be supplied directly by a battery of 24V DC (2 x 12V DC). A voltage of 24V with a frequency of 1,5KHz is supplied directly to the cable laid below ground. The magnetic field generated thus is detected by the steering antennas and the voltage induced is evaluated in the so-called track unit.

Important information:

When first put into operation, the below ground cable is typically connected first to the "(L)ong connection" terminal of the oscillator box. If the system works duly, the green LED will be lit.

First putting into operation is exclusively carried out under the presence of a BAUER technician or of an authorized dealer and it must not be carried out by unqualified personnel.

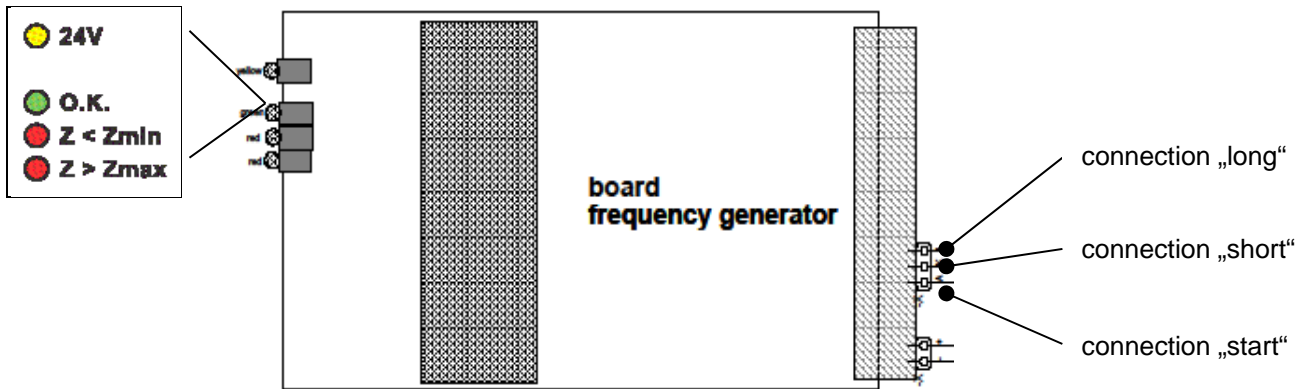

Connection "short" is appropriate for a conductor loop of max. 1 – 15 Ohm impedance and a max. current of 600 mA.

Connection "long" is appropriate for a conductor loop of max. 3 – 75 Ohm impedance and a max. current of 300 mA.

If the loop's impedance is too high, the bottommost of the 4 check lamps will be lit red. If it is too low, the lamp above (2nd from bottom) will be lit red. The signal strength is appropriate, if the 3rd lamp from bottom will be lit green.

The first check lamp indicates whether the oscillator is supplied with voltage.

After the first start, the oscillator box does not require any maintenance in normal operation. In battery operation, it is necessary to change the batteries in due time. It is recommended to use batteries with a minimum capacity of 160 Ah in order to guarantee uninterrupted operation of one week. The actual operating time depends on local conditions, that is, on the loop length and/or on the current actually consumed by the oscillator box.

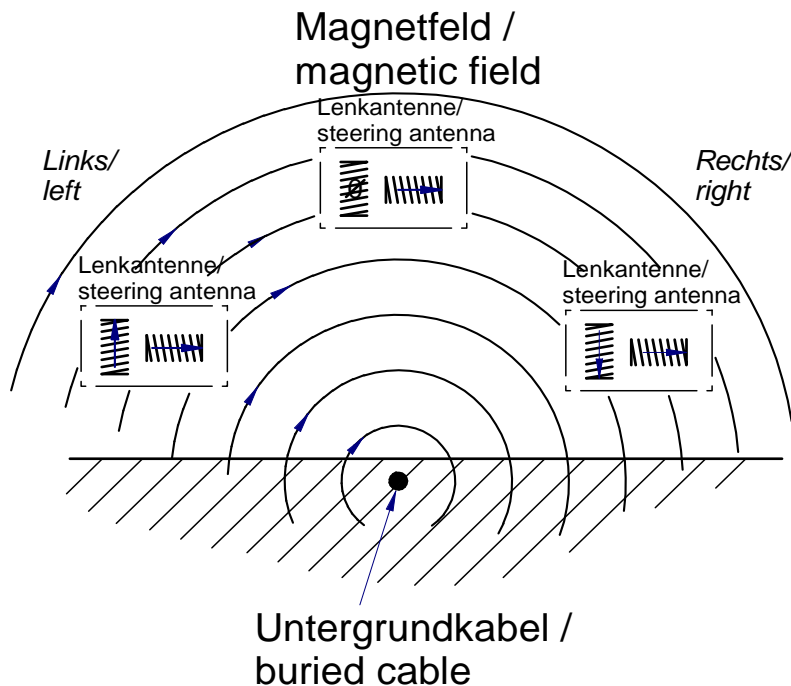

In the **steering antennas**, electric coils are installed which are able to detect lines of electric flux in horizontal and vertical direction to the ground – caused by the current passing the below ground conductor. As can be seen from the above sketch, the direction of the voltage induced in a spool changes only when the antenna moves from the left to the right side and vice versa of the below ground cable. Subsequently these signals are processed in the so-

called track unit and they are transmitted to the control centre of the system which on the other hand emits a control signal to the corresponding tower's motor if necessary. The steering antennas are connected by a 4-poles standard plug.



Steering antenna



Track unit

The steering antennas are connected to the track unit at bushes "ANT1" and "ANT2" whereby "ANT1" is provided for the front steering antenna (*seen in travel direction "Forward"*).

The track unit is connected to the control centre via a 5-poles connector plug "BUS1".

The "PWR RS232" interface serves for communication with the PC for configuration settings. For daily operation, this connection is not used. The track unit must not and/or need not be configured subsequently because it is supplied in preset condition.

"BUS2" is not used.

10.3.2 BELOW GROUND CABLE

For transmission of the below ground signal, a below ground cable with steel reinforcement especially developed for BAUER company, is used which serves above all as anti-bite protection (*against rodents etc.*).

It is pointed out expressively that perfect and long-lasting function can only be guaranteed with the original BAUER below ground cable. Multi-part below ground cables must be connected exclusively with the connecting sleeves supplied along and they must be closed so that they are absolutely waterproof. Mind that the original status of the cable at the connection point must be re-established, that is, the copper wire must be insulated duly and in addition the wire must be enveloped with the steel cover. Then the connecting sleeve can be sealed and closed.

ATTENTION: *Mind the correct connection of the below ground cable to the EARTH STRIP!*

Laying of the cable must be done by means of appropriate machines and devices in order to ensure exact straightness of the cable. The maximum cable deviation must not exceed $\pm 1,5$ cm. Be sure that there are no abrupt "changes in direction" such as buckles etc. in the cable because they would cause increased stresses in the trusses and/or in the system and they would hence lead to malfunction.

If you use an ASYMMETRIC OPEN CONDUCTOR LOOP (see 7.2.2 *Restrictions When Using an ASYMMETRIC OPEN Conductor Loop*) for the track guidance, you must run the below ground cable with a slight curve "inward" at both ends of the field because it begins to "sense" the return conductor and this would eventually lead to a deviation from the straight path.

The path of the curve depends on two factors: the height of the antenna relative to the buried cable and the distance to the return conductor at the respective end of the field. It is recommended that you initially leave the "cable ditch" open at the ends of the field. A test movement must be performed followed by any necessary corrections to ensure that the system moves correctly in a straight path. It is also important that the ground at the start and end of the field is sufficiently level because any unevenness would alter the height of the antenna and therefore alter the path of the machine as described above.

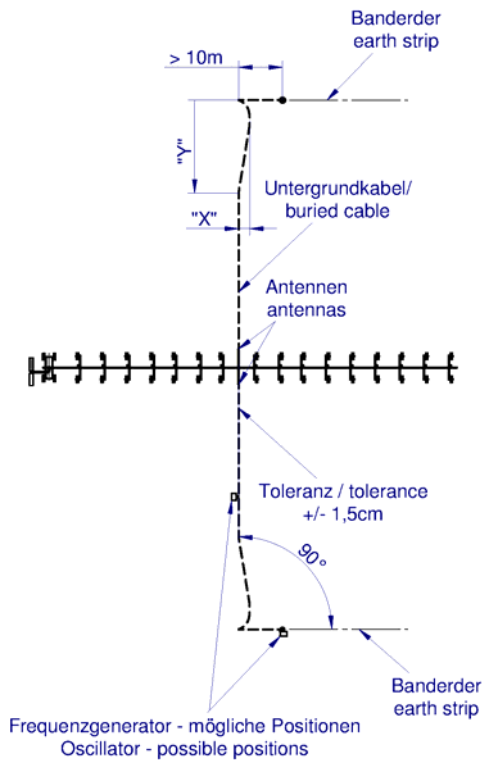

The conductor must be laid in a depth of 70 cm to 90 cm, depth which depends on the local conditions. Normally it is given by the customer.

For more detailed information about laying of the cable, see the *CABLE LAYING INSTRUCTIONS FOR BELOW GROUND GUIDANCE* under separate cover.

10.4 SETTING OF LINEAR CONTROL

Before starting, adjust the linear control system in such a way that the main cart in both directions runs parallel and at the same distance to the guiding cable or the guiding furrow.

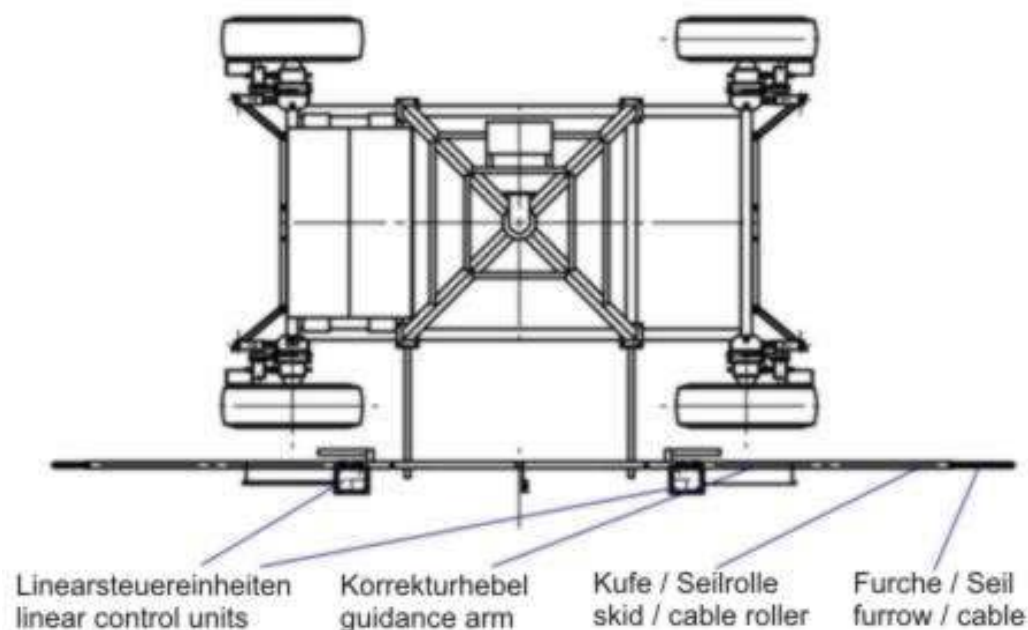

The setting of the switch points for furrow and cable guidance is basically the same.

- Position the main cart in relation to the cable or the furrow in such a way, that both control arms, when they are in their operating condition (*rollers on the cable or in the furrow*) are on a straight line with the fixed control frame of the main cart.
- Loosen the fixing screw on the control rod, which actuates the control cam of the control system, The control rod can now move freely on the guide pin.
- By moving the control rod hence and forth, the switching points of the micro-switches are determined. Every micro-switch has two switching points, a switch-on point and a switch-reverse point. Each of these switching points is marked on the guiding pin. The switching points shall be according to the following sketch:

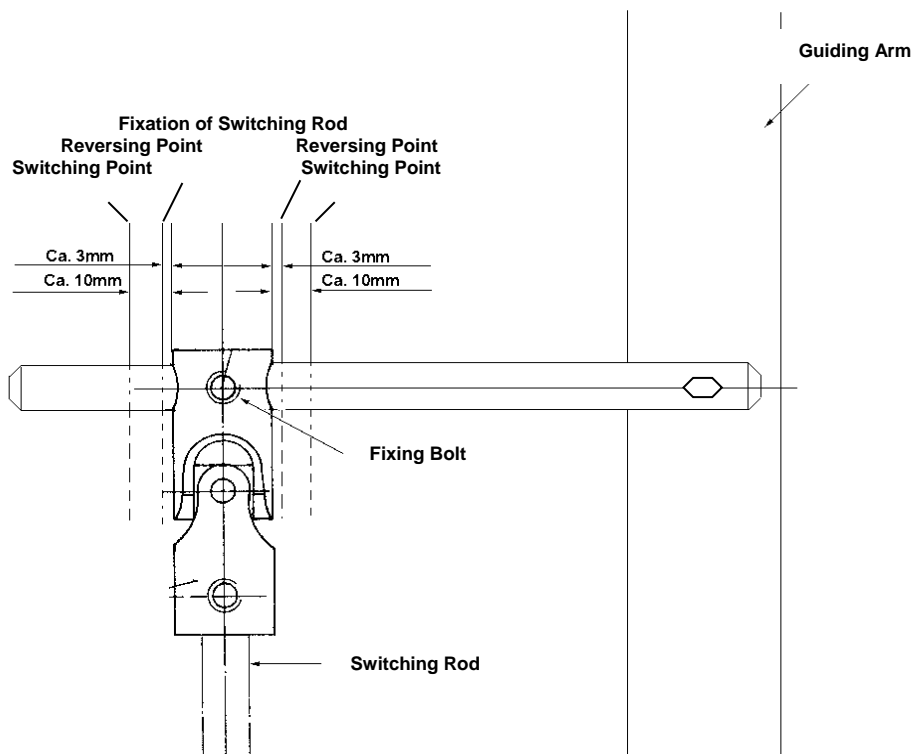

- If the distance between the end switching points of both micro-switches is too small or too large, the position of the micro switches has to be corrected and the distance between the switching points checked as to its correct value.
- If the distance between the switching points is correct, the control rod must be fixed exactly in the centre between the switching points.

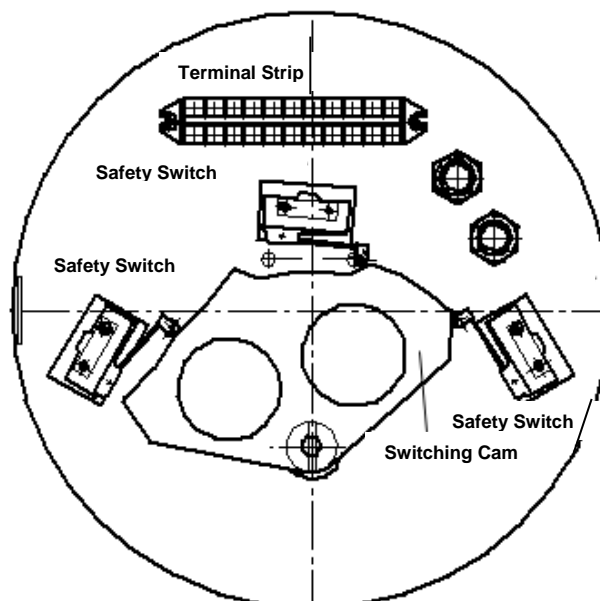

- The second linear control system must be set in the same way.

A periodical check of the exact switch points of the micro-switch (*if necessary, re-adjustment of the same*) is required for a trouble-free operation of the machine.

10.5 SETTING OF STOP SWITCH

There are switches on the main cart of the CENTERLINER, which stop the system or start the swivelling process. To activate these switches, actuation pickets must be provided along the track. The following switches can or must be mounted:

- End stop
Safety switch at the end of the field, that shuts down all functions.
- Automatic swivelling or auto-reverse.
Starts the swivelling or the automatic reverse.
- Intermediate stop
Stops the system, e.g. between 2 hydrants to change the hose connection.

CABLE GUIDANCE

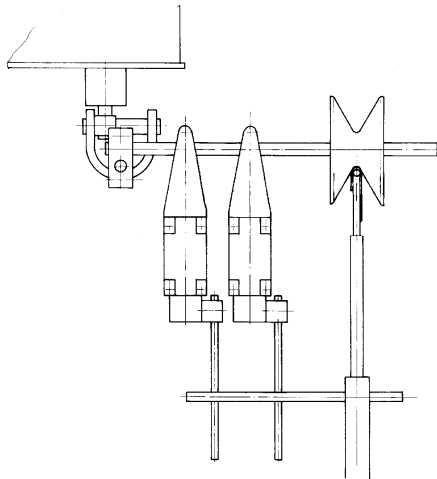

END STOP ACTUATED

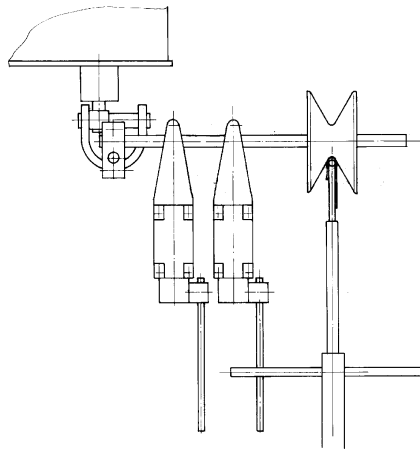

INTERMEDIATE STOP ACTUATED

FURROW GUIDANCE – switch arrangement

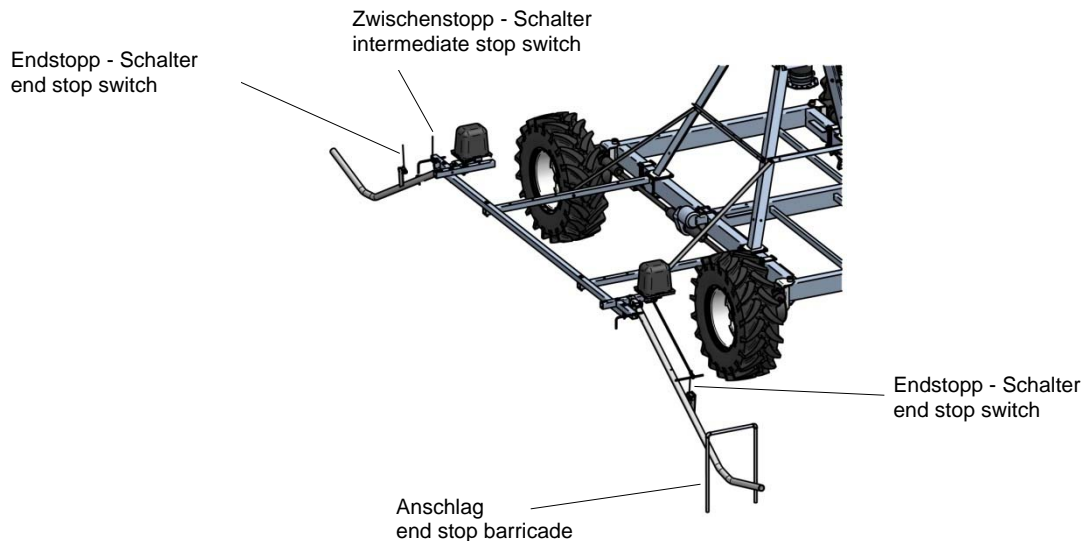

Below Ground Guidance

Switch off for CENTERLINER:

Two switches are mounted on the beam. Setting and adjustment are carried out as for the furrow guidance by means of stop pegs.

Siehe Bild **6.2.1 Components of the Below Ground Guidance.**

11 DIESEL GENERATOR UNIT

For the supply of the electric drive and control system of the CENTERLINER a diesel generator unit is mounted on the main cart. Depending on the power requirement of the system the electrical power of the unit is between 10kVA and 20kVA.

The unit is complete and consists of the following components:

- Base frame with integrated fuel tank.
- Diesel engine with electric start including battery
- Generator directly coupled to the engine.
- Unit cover
- Unit control panel with following functions and indications:
 - Three Ampere indicators (*one per phase*)
 - One voltmeter with phase converter
 - Frequency indication
 - Operating hour meter
 - Luminous indication of malfunction
 - Error indicator for oil pressure, cooling water temperature, battery charging, fuel,
 - Warning siren
 - Fuses
 - Start lock with key
 - Stop switch

12 CENTERLINER CONTROL WITH ABSOLUTE ENCODER

The absolute encoder is on the main cart in the collector. The control of the CENTERLINER guides the spans at an angle of 90° to the main cart in linear mode and it serves at the same time for absolute position recognition in swivelling mode.

The linear guidance consists of two control units / steering antennas (*Below ground guidance*) whereby always the front unit / steering antenna (seen in travelling direction) controls the wheel pairs of the main cart. The safety switch of the two control units is active in both travelling directions.

12.1 INSTALLATION INSTRUCTIONS

Please observe the below diagrams for installation and/or connection of your CENTERLINER CLX 9000 in order to ensure proper functioning. If your CENTERLINER was positioned as shown in Machine position 90°, observe and/or check the below items:

- The drive motors of the right-hand wheel pair must be connected to *M1* and *M2*, the drive motors of the left-hand wheel pair must be connected to *M3* and *M4* according to the electric wiring diagram.
- In this position, the angle value of 90° must be displayed on the control panel.

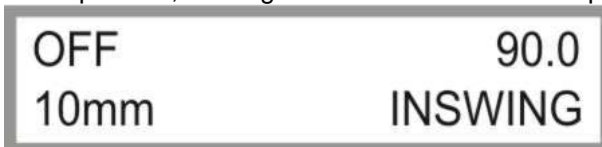

Adjust this angle by loosening the driver screw of the encoder in the collector and by turning it until **90°** are displayed on the control panel. You may also correct the angle in the machine parameter menu on the control panel. See in this context the operating instructions of the control unit *Centerliner SELECT PRO* under separate cover.

- Check the travelling directions in *LINEAR MODE*. Seen from the main cart towards the end tower, travelling direction *FORWARD* (key "**F**") is to the right and travelling direction *REVERSE* (key "**R**") is to the left.
- Check the travelling directions in *SWIVELLING MODE*. Seen from the main cart towards the end tower, travelling direction *FORWARD* (key "**F**") is a *clockwise* run and travelling direction *REVERSE* (key "**R**") is a *counter-clockwise* run.

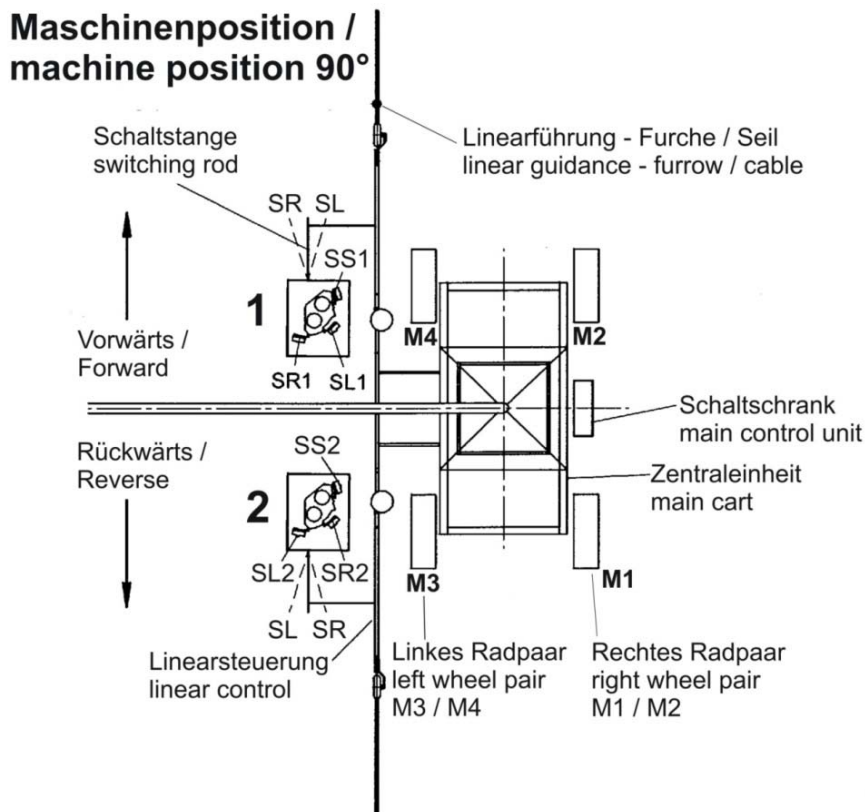

If your CENTERLINER was positioned as shown in Machine position 270°, observe and/or check the above items.

In this position, the angle value of 270° must be displayed on the control panel. If necessary, adjust the angle as described above.

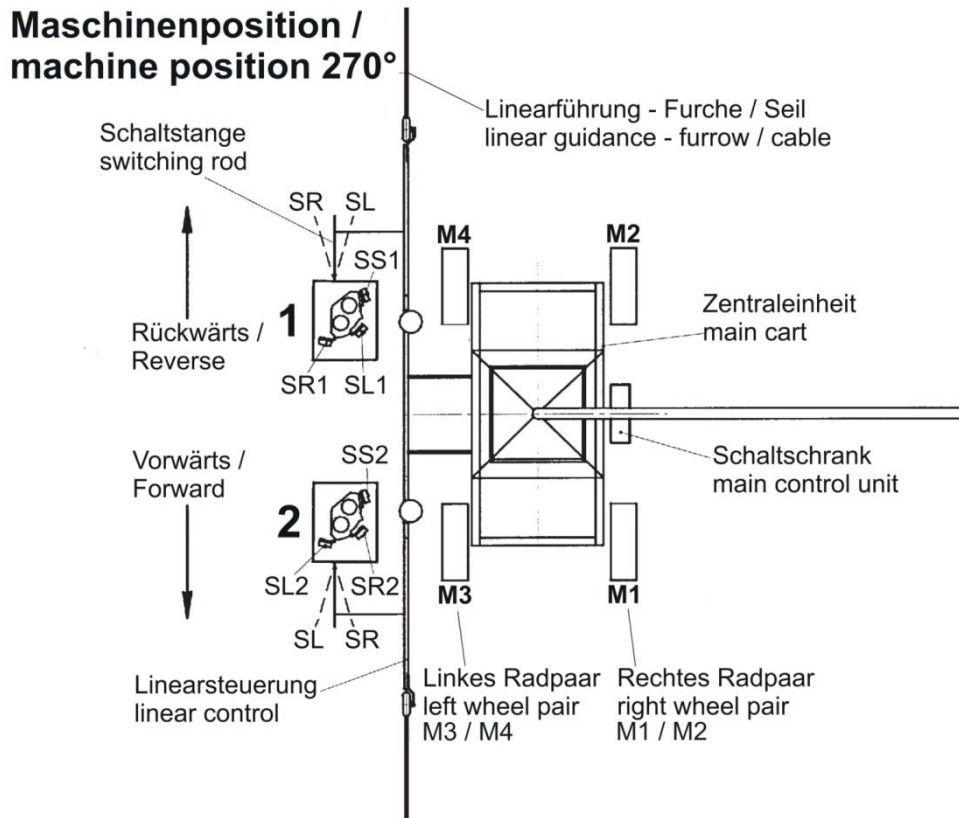

12.2 ALIGNMENT OF THE CENTERLINER AND ADJUSTMENT OF THE LINEAR CONTROL SYSTEM

12.2.1 ALIGNMENT OF MAIN CART IN PARALLEL TO LINEAR GUIDANCE (FURROW, CABLE)

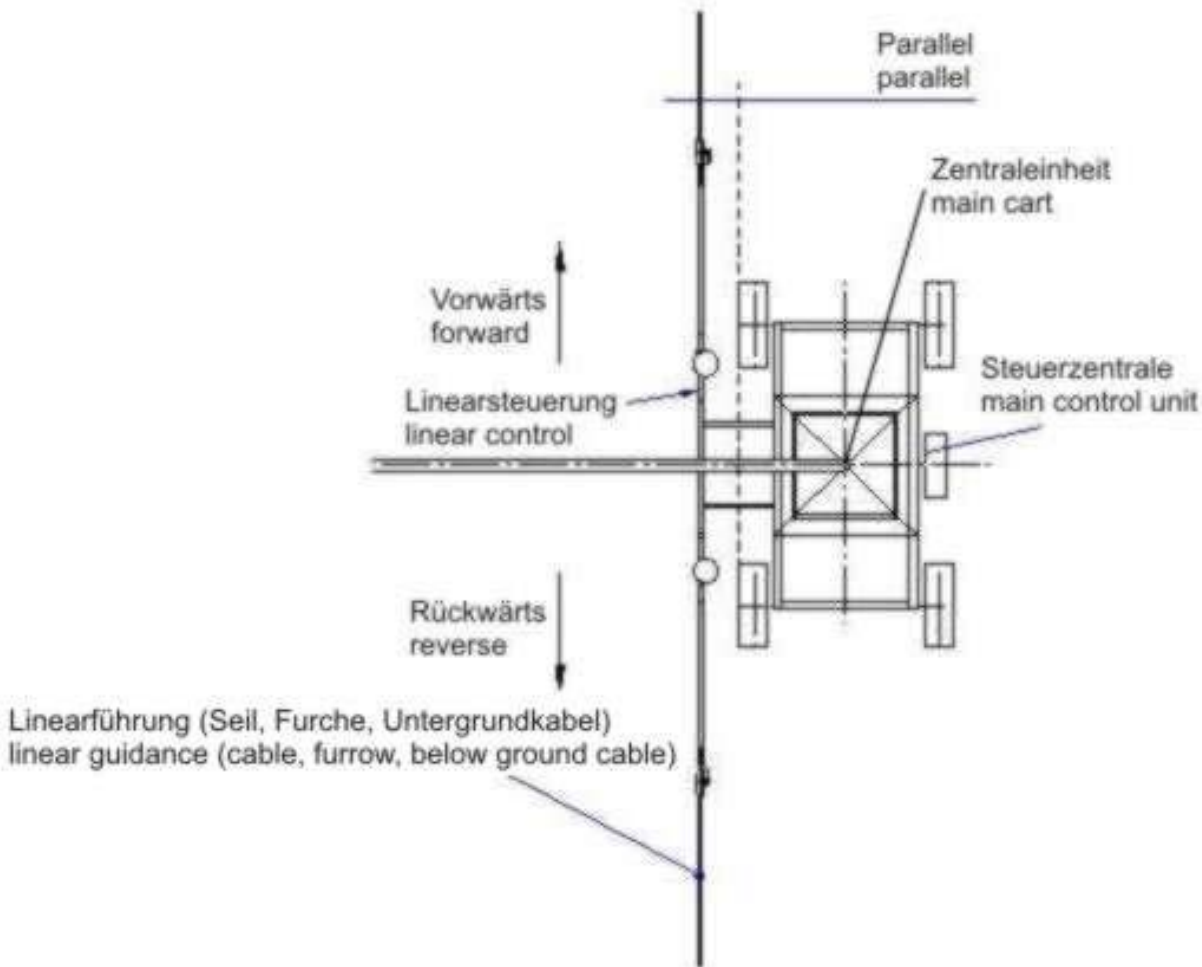

12.2.2 ALIGNMENT OF SPANS AT 90° TO MAIN CART

The imagined connection between the tower motors must be an exact straight line.

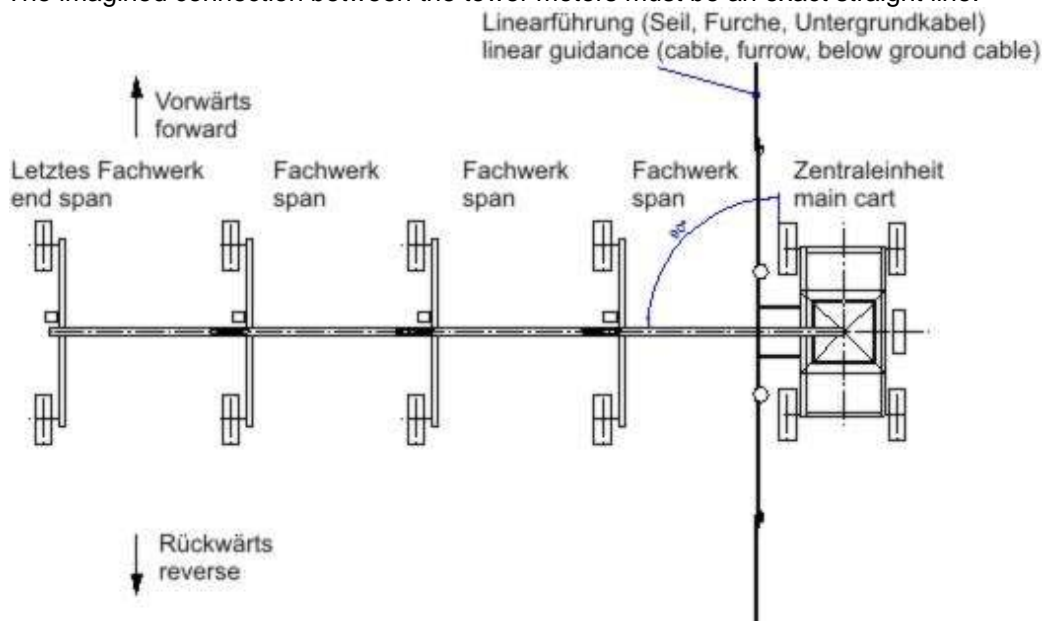

12.2.3 ALIGNMENT OF MAIN CART / SPANS TO LINEAR GUIDANCE (BELOW GROUND GUIDANCE)

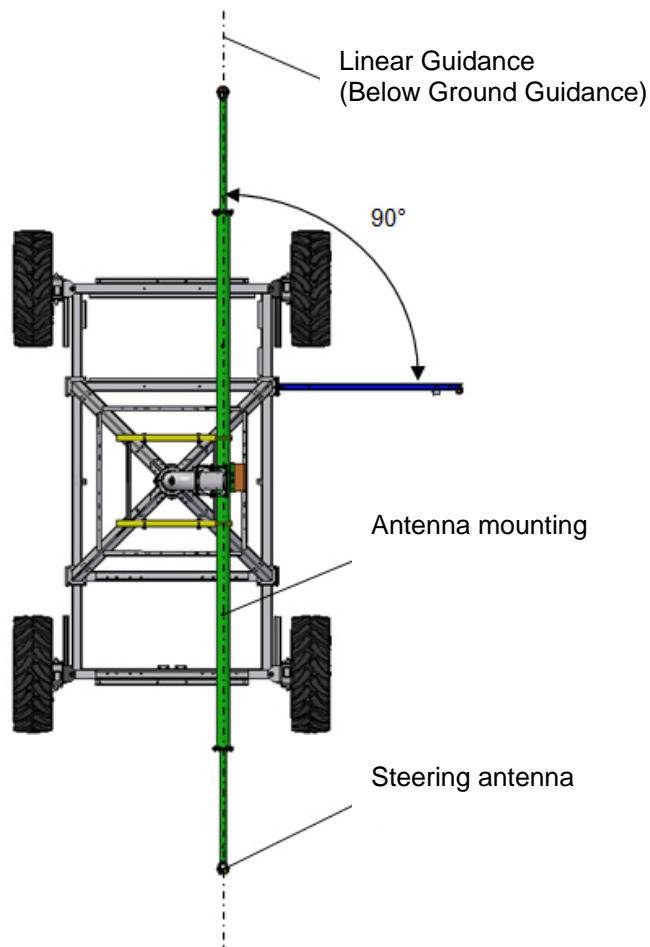

Align the SPANS 90° towards the linear guidance / below ground cable. (*The imagined connecting line of all tower engines must be an exact straight line.*)

The imagined connection between the two steering antennas must also be at 90° to the spans. At the same time, this straight line must overlap with the below ground cable, seen from top. Correctly mounted, the antennas should be as shown on the below figure.

Factory setting of the antennas has been calibrated to a height of 3 m. Mind above all the identical height of the antennas since it influences directly the linear guidance.

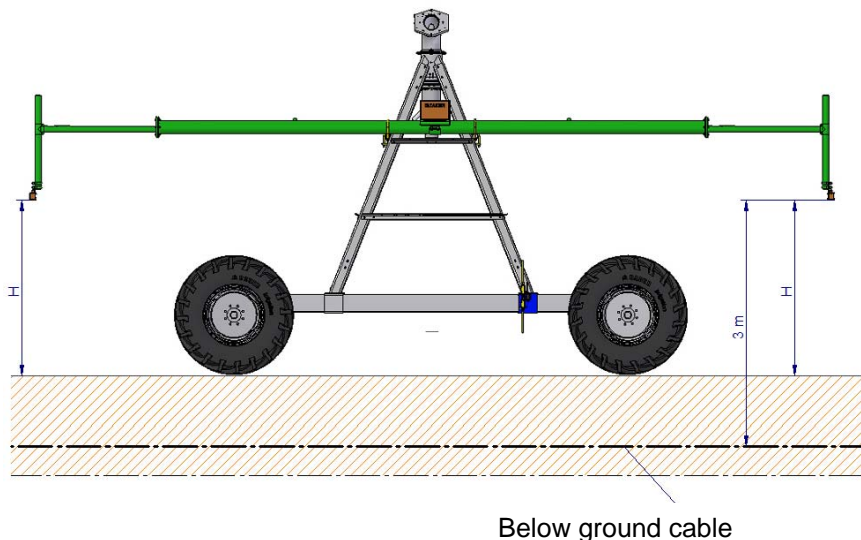

Seen from top, the antenna's front side must be vertical to the travelling direction.

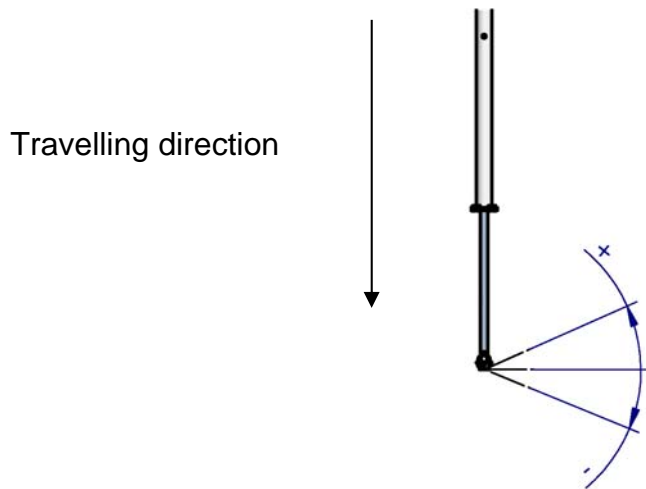

Seen in travelling direction, the antennas must be aligned to the vertical line.

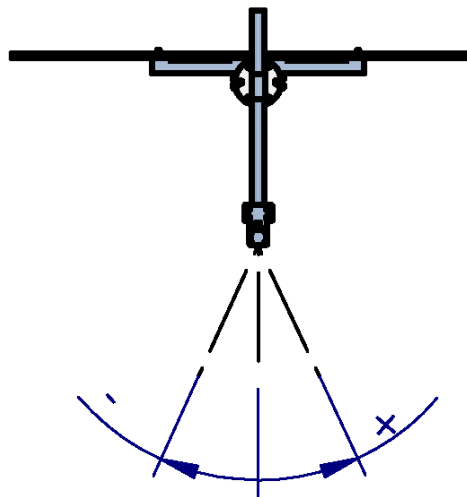

13 ALIGNMENT CONTROL

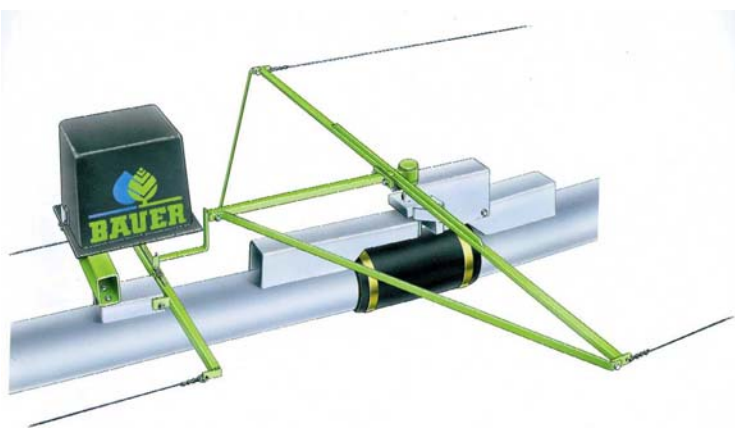

The alignment control guarantees the straight run of the CENTERLINER.

Every angular deviation between the individual spans is transmitted via a shift linkage and a control cam to the micro-switches which turn the drive motors on and off and keep the system perfectly aligned. One micro-switch is the operating switch, a second one is a safety switch which shuts the system down in case of a too large angular deviation between the spans.

In addition to the micro-switches, an RC-link is mounted, which compensates voltage peaks and protects the control elements.

A precise setting of the control elements is

required for a perfect functioning of the system.

Every alignment control directly delivered from the works is adjusted and tested. Working voltage 400 V, control voltage 230 V / 50 Hz.

13.1 MICRO-SWITCH ADJUSTMENT

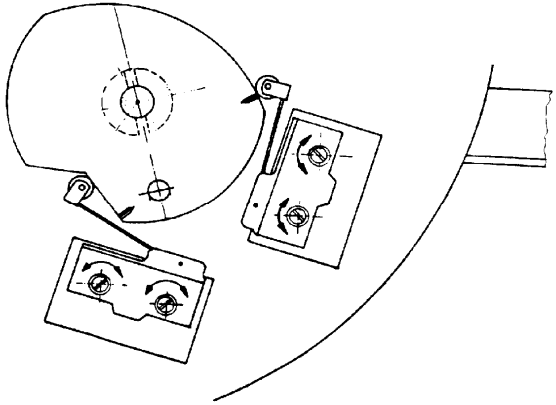

When a new micro-switch (*control or safety switch*) is mounted in a alignment control, set it precisely in the correct working position.

Disconnect the entire system from power before starting the installation.

Set the micro-switches as follows:

1. Loosen the switch fixing screw.
2. To set the control switch, rotate the control cam until the switch roller rests in the notch „A“. Adjust the switch in the bolt holes towards the control cam until the control switch (*micro-switch*) actuates (*clicks*). Thereby the bracket of the switch lies near the switch housing. Fix the switch with the screws in this position.

3. To set the safety switch, rotate the control cam until the switch roller rests in notch „B“. Move the switch toward the cam until it actuates (*clicks*). Thereby the bracket of the switch is near to the switch housing. Fix the switch in this position with the screws.

4. Check the switching points, if necessary, repeat the setting procedure.

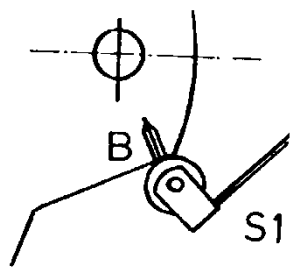
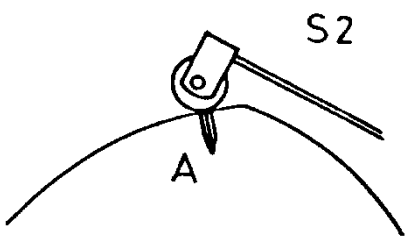



14 ELECTRICAL SYSTEM

 WARNING !	System is powered by 230 Volts and 400 Volts (460 Volts). All installation and service work must be performed with extreme care - only by a qualified person - and in strict compliance with the relevant safety codes !
---	---

 WARNING !	Complete electrical installation to be carried out ONLY with the system de-energised !
---	---

14.1 CABLES AND MARKING

1. The pivot cable consists of 11 conductors which are marked by colours.

	Conductor colour	Conductor number
Power circuit	Black	1
	Blue	2
	Brown	3
Control circuit	Pink	4
	Grey	5
	Red	6
	White	7
	Violet	8
	Green	9
	Orange	10
Grounding conductor	Yellow/green	

2. Cable lengths
The cables are cut to length and according to their execution provided with cable shoes at their ends already in the factory.
Cable lengths are selected in such a way that the two ends can be pulled into the tower boxes in a slight bend.
3. Mounting the cables
On the tower end of the span, where the alignment control is mounted on the end pipe, the cable end is laid to the end of the pipe and in this position it is fixed on the pipe with the spring clip. In this position the cable mounting length is correct on both sides.

14.2 INSTALLATION, CONNECTION OF THE PIVOT PANEL

 WARNING !	The electrical supply line must be disconnected from all power for connecting the pivot panel and for all system electrical work !
---	---

- Lay down the collector cable through the cable conduit in the feed pipe. Pull this collector cable into the pivot panel and connect it to the terminal strip according to the wiring diagram.
- Connect 3 phases of the feeding cable in the pivot panel according to the connecting diagram. (*clockwise rotating field – check with rotating field tester. In case rotating field is counter-clockwise, change 2 phases of the feeding cable on the master switch.*)
- Tighten the screwed joints at the panel inlet to prevent entry of moisture.



14.3 CONNECTION OF THE ALIGNMENT CONTROLS

1. The beginning of the pivot cable on the first span is connected to the collector. Numbering of the connections in the pivot panel, in the collector and in the alignment controls is identical.
2. Lay 3 cables into the alignment control.
incoming feeder cable,
forwarding of feeder cable,
cable to the tower drive motor
3. Connections to be made according to the enclosed wiring diagrams.
4. Distinguish between different alignment control options.

CAUTION !	Correct wiring of all alignment controls is essential. If phases were confused, the towers will travel into different directions !
------------------	--

5. Both coupling halves of the spans must be connected to the grounding conductor.
6. Tighten the screwed joints at the panel inlet to prevent entry of moisture.

15 INITIAL START-UP

15.1 CHECK-UP OF THE DIESEL PUMP GENERATOR SET

1. Diesel engine
 - a. Check the oil level.
 - b. Check whether the diesel tank contains sufficient fuel.
 - c. Check whether the air filter is properly installed and free of soiling.
 - d. Check the coolant level of the diesel engine if you have purchased a water-cooled generator.

WARNING: Also read the separate operating manual of the diesel generator set.
--

15.2 MAIN CART CHECK-UP

1. Are all screwed joints tightened?
2. Is the pivot *upper bend* in the angular support lubricated? (*recommended: Molykote BR 2 plus*)
3. Is the stuffing box gland or are the packing bolts not tightened too strongly?
4. Is the *rising pipe* in alignment with the *pivot upper bend*?
5. Do the clamps fit tightly to the counter bearing and are they tightly screwed ?
6. Are the pivot panel and the slip ring collector correctly wired ?
Test the conductive continuity by means of the circuit diagrams with a measuring instrument.
7. Are the wheel nuts of the wheels tightened? (*tightening torque 130 Nm*)
8. Is the tyre pressure:
1,5 bar with tyres 14,9 – 24
2,1 bar with tyres 11,2 – 24
0,8 bar with tyres 16,9 R 24
9. Are the gearboxes and the driving motors filled with oil?

15.3 CHECK-UP OF TRUSSING, DRIVE TOWER AND OVERHANG

1. Are all screwed joints firmly tightened? (*flanged bolts with 100 Nm*)
2. Are the ball screws of the wheels firmly tightened? (*tightening torque 130 Nm*)
3. Is the tyre pressure
1,5 bar with tyres 14,9 - 24
2,1 bar with tyres 11,2 - 24



- 0,8 bar with tyres 16,9 R 24
- Are the gearboxes and drive motors filled with oil ?
 - Are the ball joints in the tower couplings lubricated ? (*recommended: Molykote BR 2 plus*)
 - Are the electric cables fixed properly?
 - Are the cable entries moisture-tight ?
 - Are the sprinklers or spray nozzles installed in the proper position according to the supplied computer chart ?
 - Are the cables of the overhang fixed duly?

15.4 PIVOT PANEL



WARNING !

All work on electrical control system to be done only by a qualified electrician! All metal components of the CENTERLINER must be properly grounded or fitted with an electro-conductive connection with a yellow/green protective conductor!
The protective conductor must be connected to a suitable grounding (*conforming to local codes*).

15.4.1 CHECK-UP OF VOLTAGE AND WIRING

- Check mains voltage by measuring.
3-phase alternating current :
400 V +/- 5% / 50 Hz +/- 2%
or alternately 460 V +/- 5% / 60 Hz +/- 2%
- Check the control voltage on transformer (L11, N11). 230 V +/- 5%

15.5 ALIGNMENT OF THE TOWERS AFTER INSTALLATION

If the system is not precisely aligned after installation, i.e. the assumed connecting line of all drive motors is not a perfect straight line, the system needs to be aligned as follows:



- "SAFETY CIRCUIT" switch in "OFF" position.

NOTE!

The "SAFETY CIRCUIT" switch in „OFF“ position deactivates the safety system. Only switch off the safety circuit when aligning the system. If this switch is „OFF“, the system may get damaged.

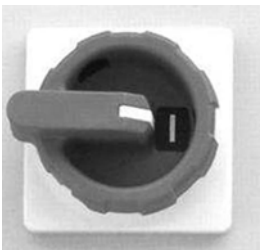

- Start generator unit, main disconnect turned to position "1", and set switch "CLE PRO" to the ON position.

- On the control panel "SETUP" will be displayed.
- Press key "F" (*FORWARD*) and/or "R" (*REVERSE*) for the requested travelling direction.

Mind the pick-up noise of the individual contactors in the control cabinet.



- Align the towers flush with the centre tower by using the tower alignment switch (take aim on drive motors).

NOTE!

In order to prevent a mechanical overload of the truss, align the Centerliner step by step starting at the system end. The assumed connecting line between all tower motors with the centre of the centre tower must be perfectly straight.

15.6 ADJUSTMENT OF ALIGNMENT CONTROL UNITS



ATTENTION!

Make sure yourself that the main disconnect Q2 is set at „0“ and that the generator unit is turned off. Secure the switch against a reclosing with a padlock on the switch or lock the door of the control box.

An important prerequisite for adjusting works is that the spans are all aligned.

If this is the case, use the bolts on the threaded rod to adjust the operating cam until the roller of the control switch is positioned exactly in the middle between switching point, notch „A“, and reversing point (between both clicks). This guarantees the same control angles in FORWARD and REVERSE run.

The micro-switches are adjusted as follows:

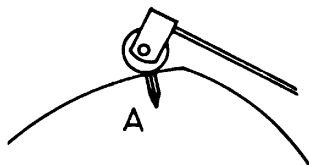

- Turn the control cam by turning the hexagonal nut on the threaded rod until the control switch lies in the notch „A“ and actuates.

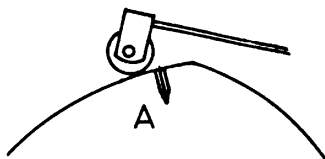

- Rotate the control cam clockwise by turning the hexagonal nut on the threaded rod to the reversing switch point (click) of the control switch, counting the number of rotations of the nut or wrench turns.

- Turn back the control cam by half of the counted nut or wrench rotations counted under point 2 above, so that the switch roller is positioned exactly in the middle between switching and reversing point of the control switch.

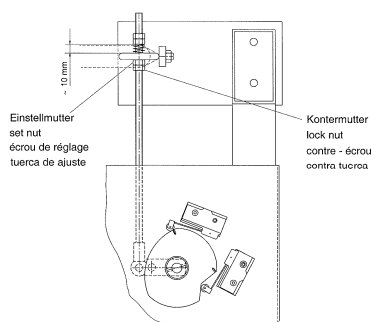

- Secure the set nut with the lock nut on the threaded rod. Adjust both other nuts in such a way, that the spring is pretensioned about 10 mm.



A periodical check of the exact switching points of the micro-switches (*if necessary, re-adjustment*) is required for a trouble-free operation of the machine.

15.7 ALIGNMENT CHECK-UP

The CENTERLINER is best aligned, if there is a slight regular forward bow in travel directions.

If this is not the case, realign the system as follows:

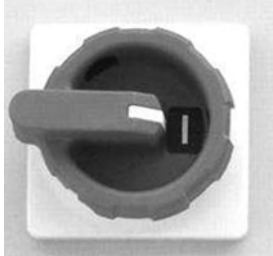

1. Start generator unit, turn main disconnect Q2 to "1".



2. Turn "SAFETY CIRCUIT" switch "ON".

During the operation this switch MUST always be „ON“ !!
This is the only way to guarantee safety during unattended operation.



3. Turn switch "CLE PRO" to "ON".

4. On the control panel change to *LINEAR* operating mode. Start the CENTERLINER with key "F" (*FORWARD*) and/or "R" (*REVERSE*).

5.

- a) Check if the driving motor of the first tower is located **in front of** an assumed connecting line between the drive motor of the second tower and the centre of the centre tower. If this is not the case, the tower box on the first tower must be readjusted as follows: Loosen the hexagonal nuts and turn the threaded rod until the above requirement is fulfilled.
- b) The next step is to check if the drive motor of the second tower is positioned **in front of** an assumed connecting line between the drive motor, the third tower and the centre of the centre tower. If this is not the case, correct the tower box on the second tower.
- c) Now check all the towers step by step as described under a) and b). Re-adjust tower boxes, as needed. At the end of this procedure, the CENTERLINER should form a positive bow, which means that the middle tower must be positioned in front of an assumed connecting line between end tower and centre tower.



6. Turn main switch to "O".

15.7.1 CHECK OF TOWERS' TRAVELLING DIRECTION AFTER ALIGNMENT

- Turn the "SAFETY CIRCUIT" switch to "ON".
- Start the generator unit.
- Switch on the power supply with main switch Q1.
- Switch "CLE PRO" to "ON".
- On the control panel, set "PIVOTING" mode.
 - Press key "F" (*FORWARD*) on the control panel. The main cart stops. The system must start *clockwise*.
 - When pressing key "R" (*REVERSE*) on the control panel, the system must start *counter-clockwise*. The main cart stops as well.
 - ❖ If the travelling direction did not correspond to the preselected travelling direction in any of the towers, the 2 phases of the main supply line will have to be interchanged in the main disconnect Q1 after switching off the power supply.
 - ❖ If only some towers travelled into the wrong direction, the polarity of the motor connecting cable of the tower concerned will have to be changed after switching off the power supply.
- On the control panel, set "LINEAR" mode.
 - Press key "F" (*FORWARD*) on the control panel. The system must start *FORWARD*.
 - When pressing key "R" (*REVERSE*) on the control panel, the system must start in *REVERSE* direction.
 - ❖ If the left pair of wheels of the main cart started into the wrong direction, the polarity of the motor connecting cable of the left drive motor will have to be changed after switching off the power supply.
 - ❖ If the right pair of wheels of the main cart started into the wrong direction, the polarity of the motor connecting cable of the right drive motor will have to be changed after switching off the power supply.

Warning: It is essential to mind the figures in chapter **12.1 Installation instructions**.

Warning: When the system *travels into the wrong direction*, stop the machine immediately!

16 TERMINOLOGY

Forward

Looking from the main cart to the end of the system, the CENTERLINER runs to the right or when swivelling the plant the CENTERLINER runs clockwise.

Reverse

Looking from the main cart to the end of the system, the CENTERLINER runs to the left or when swivelling the system the CENTERLINER runs anti-clockwise.

Inward

Direction main cart

Outward



Direction last tower

Positive bow hurrying ahead

If the middle towers are in front of an assumed, straight line in travel direction between main cart and end tower.

Negative bow hurrying backward

If the middle towers are behind an assumed, straight line in travel direction between main cart and end tower.

Dogleg

Happens, when a tower gets slower or stands still resp. hurries on ahead of the other towers.

17 START-UP

The CENTERLINER is only to be released for operation to the customer after it has been completely assembled and installed and after a successful start-up is completed by a qualified person!

As the plant is operated with voltages of 400 V or 460 V, the control components and the electric drive need to be handled with the utmost caution ! Service and repair works should only be done by a professional electrician!

Before starting the system, check if all hooked up generator units (*generators*) are ready for operation. Have the responsible service centre repair possible damages, before you start irrigating. Be extremely cautious with live parts.

The starting as described below is valid for a BAUER CENTERLINER without options. In case the system has various options (*see chapter options*), these should be set or switched on before the start-up.

If you have purchased a CENTERLINER with Below ground guidance, be sure that the oscillator box is supplied with voltage.

With a 230V AC supply, put the main switch of power supply to position "1".

With a 24V DC battery supply (2 x 12V DC), check if the batteries are connected and sufficiently loaded.

17.1 STARTING PROCEDURE WITH CONTROL PANEL SELECT PRO

17.1.1 START

- Connect the supply hose to hydrant and main cart, open water supply.
- Turn the disconnect GENERATOR STOP to OFF.
- Start the generator unit.
- Turn MAIN SWITCH to ON.
- Set the desired precipitation rate on the control panel.
- Turn the SAFETY CIRCUIT to ON.
- Set the desired operating mode on the control panel: *LINEAR*, *INSWING*, *OUTSWING* or *PIVOTING*.
- Turn switch CLE PRO to ON.
- Switch END GUN to ON (*if you have purchased a system with end gun*).
- Set the desired precipitation rate on the control panel.
- Set the desired operating mode on the control panel: *LINEAR*, *INSWING*, *OUTSWING* or *PIVOTING*. If necessary, set AUTO STOP to ON or OFF (*see also 6.1 CENTERLINER OPERATING MODES*).
- As desired, press "F" (*FORWARD*) or "R" (*REVERSE*).
- The CENTERLINER starts operating.
If the switch END STOP or INTERMEDIATE STOP is actuated, keep the start button pressed until the main cart has moved out of the operating range of the switch.

WARNING:

As long as the switch END STOP or INTERMEDIATE STOP is actuated, you must set the switch SAFETY CIRCUIT to OFF to be able to move the system from this area. Set the switch SAFETY CIRCUIT back to ON immediately afterward to ensure safe operation of the CENTERLINER.

- Turn GENERATOR STOP to ON.

WARNING: Also read the separate operating manual of the control panel SELECT PRO.

17.1.2 START AFTER INTERMEDIATE STOP

In certain cases it is required to stop the CENTERLINER along an irrigation strip, i.e. if the supply hose needs to be connected to another hydrant or if only a partial area has to be irrigated.

In this case a shut-down sensor is actuated with a switching peg and thus turned off.

The shut-off valve in the riser pipe (*option*) is closed, the generator unit is shut down, when the switch GENERATOR STOP is ON.

NOTE!

If there is no shut-off valve mounted on the CENTERLINER, i.e. no shut-off system is provided, the system continues irrigation at a standstill and the water supply must be closed manually.

- Turn switch GENERATOR STOP to OFF.
- Set the switch CLE PRO to ON.
- Set the switch SAFETY CIRCUIT to OFF.
- Start the generator unit.
- Press the button "F" (*FORWARD*) or "R" (*REVERSE*) for the desired direction of travel. Listen for the engaging noise of the respective contactor in the switch cabinet.
- Press and hold the buttons "+" and "-" on the operating panel. The system will move in the previously selected direction.
When the main cart has moved out of the switching area of the switch, you can continue the typical irrigation operation.
- Set the switch SAFETY CIRCUIT to ON.
- Start the system with the button "F" or "R".
- Turn switch GENERATOR STOP to ON.

17.1.3 SWIVELLING THE CENTERLINER CLX 9000

In *LINEAR* mode, the *CENTERLINER* automatically stops at the end of the irrigation strip.

If you want to swivel the system automatically inward or outward at the end of field, select one of the two operating programs *INSWING* or *OUTSWING*.

If automatic swiveling of the boom by 90° at the end of the field is desired, use the two programs *INSWING* or *OUTSWING* and set the parameters "SECTORP.L" or "SECTORP.R" in the machine parameter menu to 180° or 0°.

If you want to run the *CENTERLINER* exclusively in *swivelling mode*, select operating mode *PIVOTING*.

See in this context the operating instructions for *CONTROL PANEL SELECT PRO*.

17.1.4 SWIVELING THE CLX MAIN CART

- Lift the skids of the correction control box and attach these to the beam with the linch pins.
- Turn the switch SAFETY CIRCUIT to OFF.
- Turn the switch GENERATOR STOP to OFF.
- Start the generator.
- Turn the main switch to setting "1".

The following appears on the display of the PRO control panel:





No function is stored under "M0". Switch between the motors "M1" to "M4" of the main cart (see also 12.1 *INSTALLATION INSTRUCTIONS*) by pressing the two arrow buttons of the control box (*manual control*) on the main cart at the same time.

Setup M1

- Remove the locking strut that connects the motor bracket with the frame of the main cart.
- Press the arrow buttons of the control box to swivel the respective wheel into the intermediate position.
- Connect the locking strut to the frame of the main cart again.

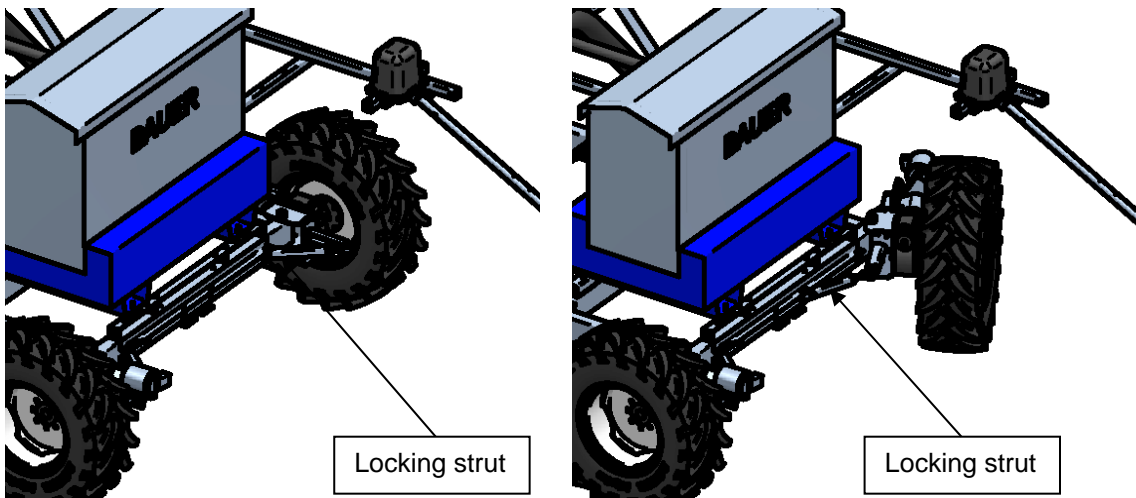

- Proceed as described above to swivel all 4 wheels of the main cart into the intermediate position.

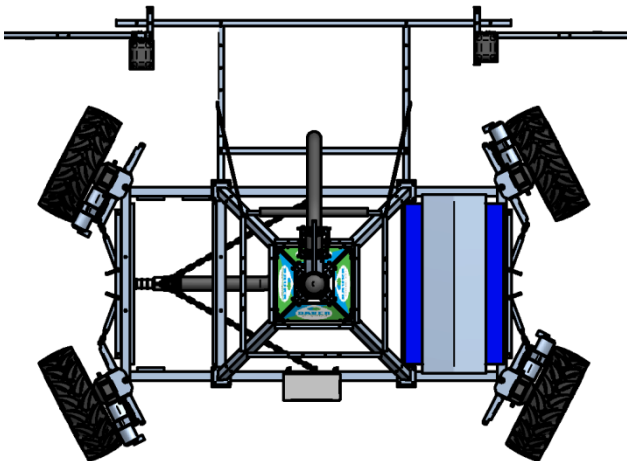

- Switch to "M5" by pressing both arrow buttons of the control box (*manual control*) on the main cart at the same time.

Setup M5

- Press the arrow buttons on the control box to swivel the entire main cart by 90°, for example.
- Then swivel the wheels of the main cart back to the initial position.
- Lower the skids of the correction control box.
- Turn the switch SAFETY CIRCUIT to ON.
- Turn the switch GENERATOR STOP to ON.
- Switch off the machine or start the desired operating program.

17.1.5 SHUT-DOWN PROCEDURE

- Shut down the CENTERLINER while irrigating, by pressing the "STOP" button on the control panel
- If GENERATOR STOP is turned to ON, the generator unit shuts down as well. If the switch is turned to OFF, the generator unit must be turned off separately.
- Interrupt the water supply by shutting down the pumping unit or closing the gate valves.

17.2 ALIGNMENT OF THE SYSTEM

17.2.1 ALIGNMENT OF THE MAIN CART

1. If the main cart is not parallel to the control furrows or the control cable, the main cart must be aligned or put parallel to the control furrow or control cable.
2. If the linear control or the main control is in the safety circuit, the safety circuit has to be interrupted. (*Switch 12*) OFF
3. Determine, if the operating range of the linear control is positioned correctly, i.e. the control arms in the operating range are aligned with the frames of the main cart. If that is not the case, the micro switches have to be re-positioned. Setting as per instructions.
4. Get the boom to the main cart with operating mode *PIVOTING*.
5. In program 1 (*linear*) run system with main cart forward or reverse. Main cart gets more and more aligned parallel to the control furrow or control cable.

NOTE:

Take care that, while aligning, the angle between the main cart and the boom remains close to 90°. If the main cart gets too far off, the boom has to be re-set with operating mode *PIVOTING*. That way, a tension in the system is avoided.

17.2.2 ALIGNMENT OF THE BOOMS FOR LINEAR MODE

Swivel the boom with operating mode *PIVOTING* until boom is at 90° to the main cart.

18 HOSE SUPPLY CLE / CLX

With the central units CLE and CLX, you can continue travel at the end of the field in the opposite direction after an automatic swivelling movement without having to switch the supply hose.

This is made possible by a special hose guidance system beneath the central unit. The "pulled" supply hose is disconnected from the "laid down" supply hose, enabling flawless operation even at a low supply pressure. The hose guidance system can be reconnected at different locations and is required at the respective outer hydrants (*automatic reversal at the end of the field*).



If the CENTERLINER operates only in the area of a single hydrant, this mechanism permits fully automatic operation of the system. No switching of the supply hose connection is required.

Situation Zuführschlauch

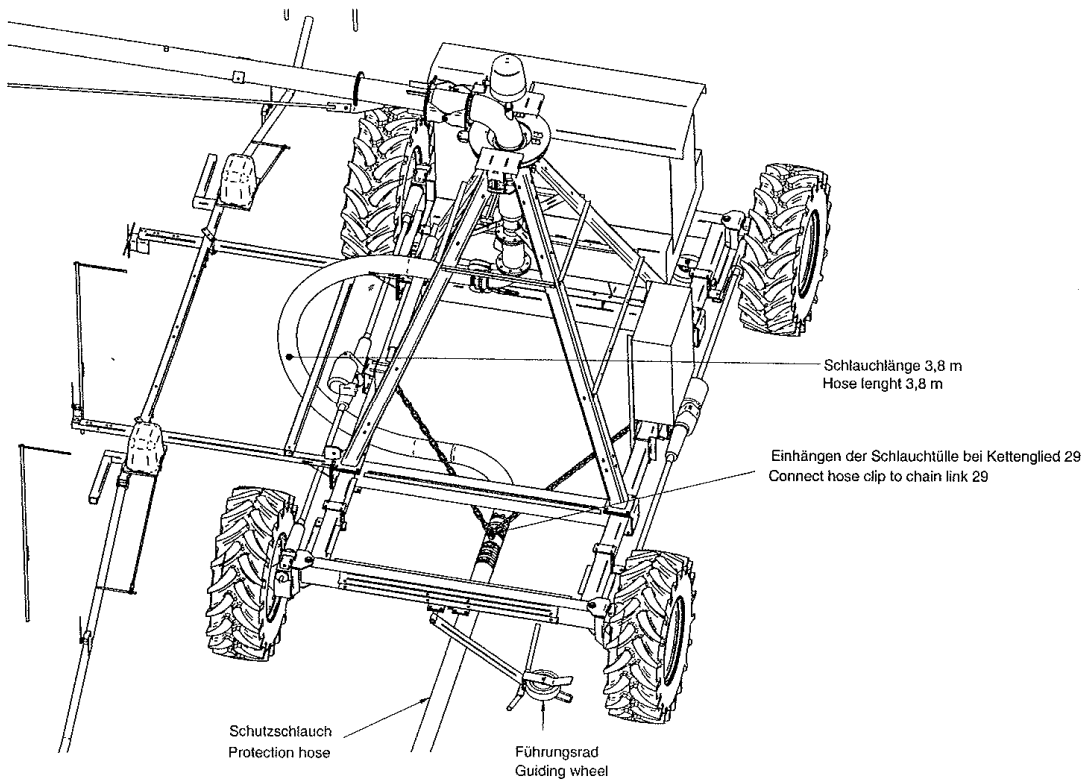
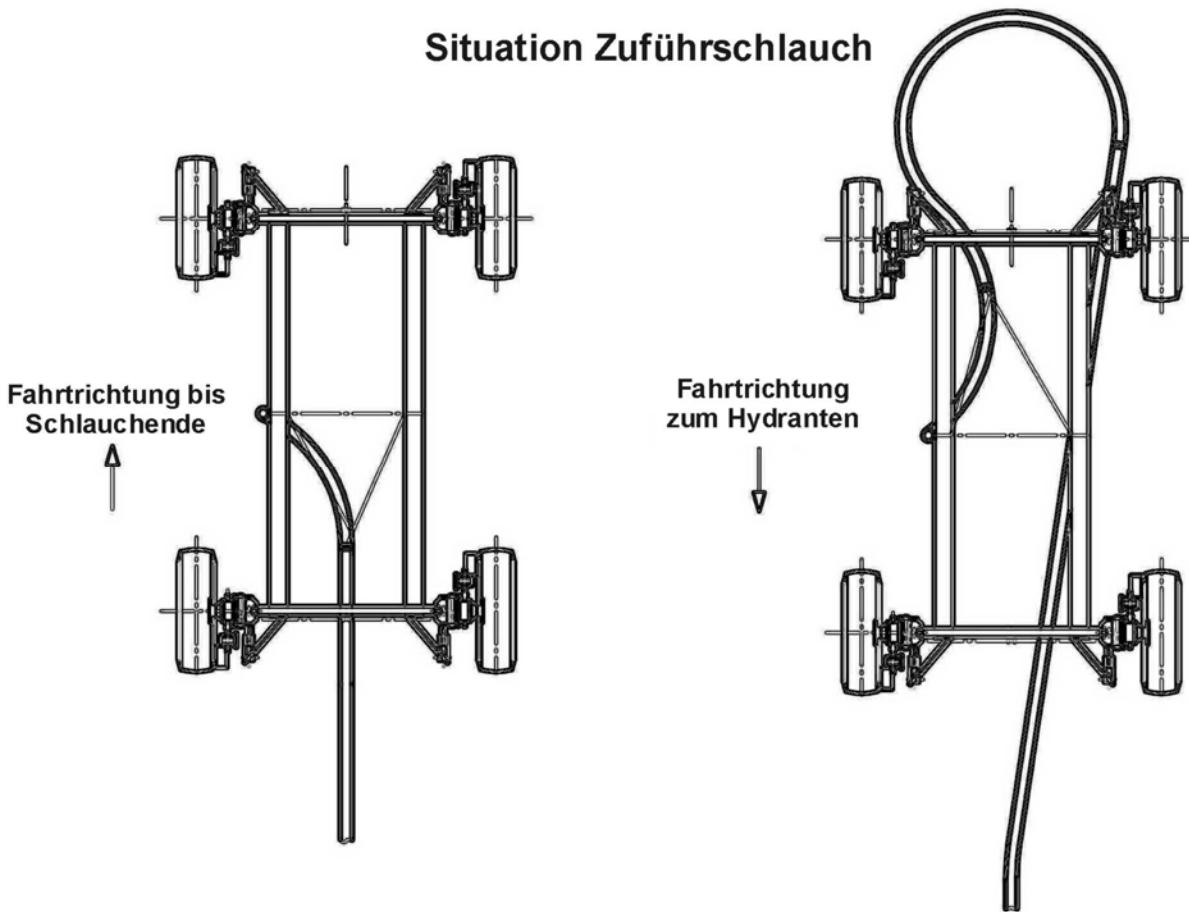

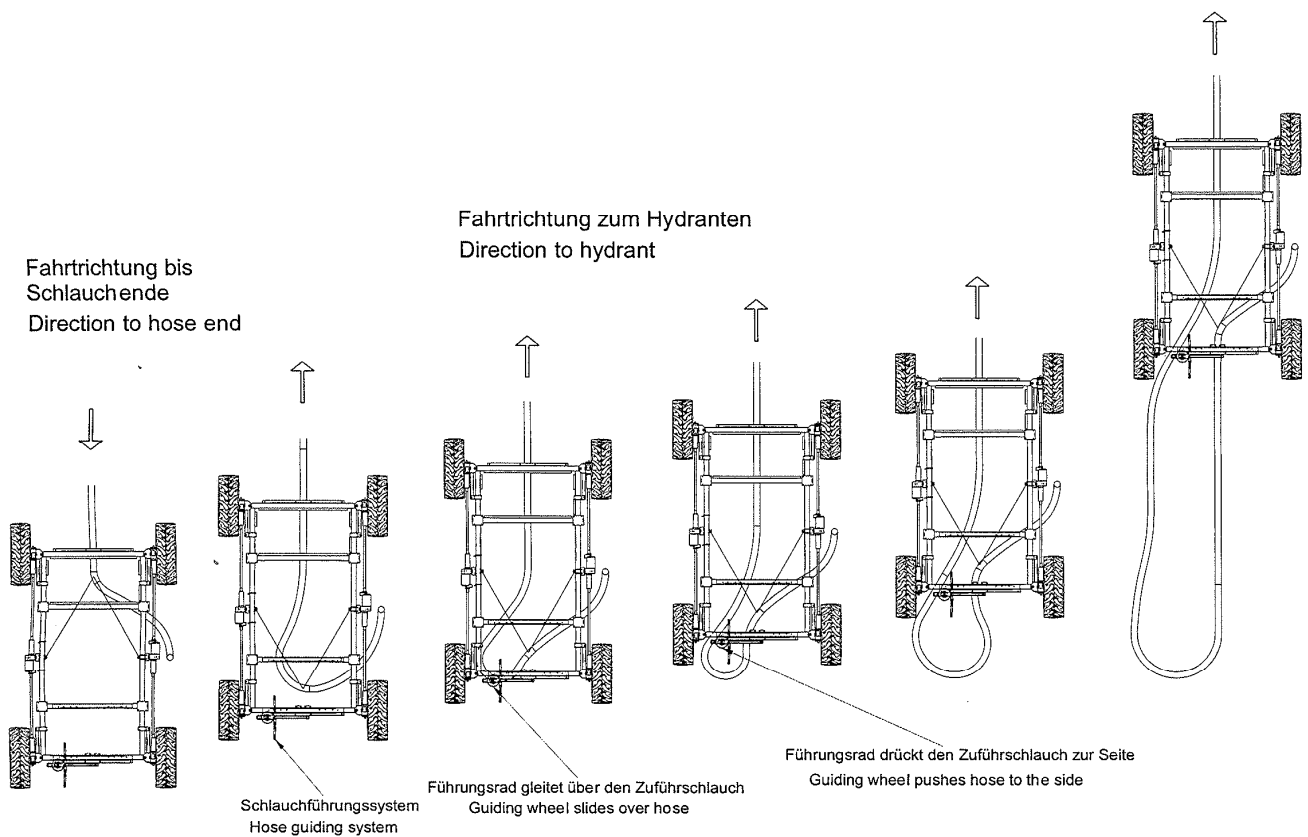

19 MAINTENANCE INSTRUCTIONS

Notice

Warranty claims will only be accepted if rules of handling and maintenance (*according to service plan*) has been followed. Service should be done by an authorised dealer and confirmed in the service plan. The service plan is considered as evidence for warranties.

The meaning of service plan

The service plan suggests when to do a service and what kind of service should be done.

In the fields that provides evidence we confirm the carrying out of the service. This services can be a condition for possible warranty claims.

We kindly ask you to understand that natural wear and damages due to inroad, improper handling or inadmissible changes are not included in the warranty.

- Always disconnect the system from all power before starting any maintenance work. Turn the main switch to "0" and activate the safety lock-out to prevent unauthorised or unintentional re-closing of the system. Always disconnect the system yourself - do not depend on other persons. In case of different voltage supply for the oscillator box (*Below ground guidance*), separate this supply as well.
- Always re-mount all protective devices dismantled during maintenance.

19.1 Service intervals

- Monthly service
- Annual service



20 SERVICE PLAN

Extent of Service	Monthly Service	Annual Service
Central tower		
- Check all screwed joints as well as the pivot hold down		X
- Controlling the sealing ring in the riser pipe on leakage (<i>replace if necessary</i>)		X
- Lubricate upper bend rotating in the supporting angle.	X	X
- Check the stuffing box packings of the cable conduit		X
- Check if electric cable entries into the pivot panel are tight		X
- Check full-surface contact of brushes with rings in the slip ring collector		X
- Check collector brushes and slip rings for signs of wear		X
- Check condition of all electric connections as well as tightness of the collector housing		X
- Check smooth running of collector bearing and verify that the driver is isolated from power		X
- Check operation function of switch for end stop, automatic reverse and end gun sector control	X	X
- Check all screwings on the encoder in the slip ring collector	X	X
Trussing, overhang, coupling		
- Check all screwings on flanges, truss rods, braces, on towers and on overhang		X
- Check tightness of the flexible hose of tower couplings.		X
- Lubricate ball joint of the drive tower coupling	X	X
- Empty sand trap	X	X
- Booster pump – turning of the shaft between engine and pump – check if runner of the pump pivots without problems.		X
- Check end gun (<i>if existent</i>)		X
Alignment control, transmission device		
- Check and adjust (<i>if necessary</i>) the switch cam		X
- Check shifting travel of the micro switch	X	X
- Check function of micro switch (<i>operation switch and safety switch</i>)		X
- Check all electric connections on safe contact		X
- Check tightness of all cable entries into the tower box		X
- Check tightness of alignment control cover		X
- Lubricate the ball joints of the transmission devices	X	X
- Exact control – Check tightness of guiding cables		X
- Sight control of alignment of the spans	X	X
- Check straightness of guiding track (<i>cable, furrow</i>)	X	X
- Check smooth running of the guiding rolls of the cable guidance	X	X
- Check distance and parallelism of main cart to furrow-, cable guidance	X	X



Extent of Service	Monthly Service	Annual Service
Drive unit		
- Check oil level of gearbox and drive motor		X
- Change oil after first irrigation season, then after every third irrigation season		X
- Gearbox: Make sure that drainage holes on the bearing covers and the hole for ventilation on the expansion chamber are not blocked.		X
- Gearbox Type TNT – Lubricate the bale assembly	X	X
- Drive motor: Make sure that the drainage hole at the bottom of the motor is not blocked.		X
- Gearbox, drive motor - check tightness of shaft sealing ring	X	X
- Lubricate outside hubs of towable gearboxes		X
- Check screw connections of the driveline coupler		X
- Check if rubber packages of driveline coupler are damaged. Replace worn out and broken rubber packages.	X	X
- Check wheel nuts	X	X
- Check tire pressure: 1,5 bar with tires 14,9 – 24 2,1 bar with tires 11,2 – 24 0,8 bar with tires 16,9 – 24	X	X
- Make sure that tires are not damaged		X
- Check anti twist device of axle drive shaft cover	X	X

20.1.1 POST-SEASON MAINTENANCE

1. Remove the drain valves and plugs in the pipeline.
2. Open sand trap stop valve.
3. Flush the pipelines.
4. Mount the drain valves and plugs again and close the sand trap stop valve again.
5. Take away the supply hose from the irrigation field and stock it in a building.
6. Empty the cooling liquid of the generator unit or check if sufficient anti-freeze is added.
7. Optional: For systems with below ground guidance, separate the voltage supply of the oscillator box and/or dismount the battery and store it winterproof.

20.1.2 PRE-SEASON MAINTENANCE

Check pivot panel and tower boxes for damage by oxidation or rodents and insects.

1. Open sand trap stop valve and flush the pipelines.
2. Check tightness of flange seals and connecting hoses.
3. Close sand trap stop valve again.
4. Tension cable for cable guidance and align pegs
5. Draw a new furrow for the furrow guidance
6. Place and align the pegs correctly for intermediate stop and end stop
7. Unwind the infeed hose and check its density
8. Fill in the cooling liquid at the generator unit resp. Fill it up, check motor oil
9. Further checks => CHECKLIST
10. Optional: For systems with below ground guidance, branch the voltage supply of the oscillator box and/or mount and branch the battery.



20.1.3 PRETENSIONING FORCES AND TIGHTENING VALUES OF BOLTS

The listed pretensioning forces and torques are guiding values for standard metric threads according to DIN 13 and head contacts according to DIN 912, 931, 934, 6912, 7984 and 7990 as well as threads based on inch-system rough (*UNC*) and smooth (*UNF*). They result in a utilisation of the screws' yield point of 90°. They are based on a friction factor of 0,14 (*new bolt, not reworked, unlubricated*).

Screws standard metric thread DIN 13			
dimension	quality	torque Nm	pretensioning force N
M 5	8.8	6,0	6360
M 8	8.8	25,5	16230
M 10	8.8	50	25791
M 12	8.8	87,3	37657
M 14	8.8	138,3	51681
M 16	8.8	210,8	71196
M 20	8.8	411,9	111305
M 24	8.8	711	160338

Screws UNC standard thread			
dimension	quality	torque Nm	pretensioning force N
1/4"	S	12,5	10080
5/16"	S	21,3	13954
1/2"	S	92,7	38463

Screws UNF standard thread			
dimension	quality	torque Nm	pretensioning force N
9/16"	S	150	57143

Do **not** fasten the bolts 1/2" UNC for tightening the wheel gears with a power screwdriver. There may be a danger in damaging the thread in the gear casing.



21 TROUBLESHOOTING

FAULT	POSSIBLE CAUSE	REMEDY
Machine has switched off automatically: a) Generator unit	lack of fuel low battery loose connecting terminals lack of cooling liquid low oil pressure loose V-belt	fill in fuel recharge battery tighten terminals fill up liquid oil filter dirty fill up lubricating oil tension V-belt
Machine is in safety circuit:	doglegging bad machine equipment defective micro-switches obstacle in track switch for intermediate stop has been actuated FI relay has released through short to ground on system power supply oscillator box interrupted	see re-start after doglegging correction by trained service personnel replacement, removal remove obstacle and/or set stop lever correctly confirm FI relay (<i>blue reset key</i>) check, recharge battery if necessary
Leakage: - stuffing box - upper bend - pivot or tower coupling	loose packing gland lip of seal ring damaged O-ring not inserted properly loose hose clamp	tighten screw exchange seal ring insert O-ring properly tighten hose clamp
Slip ring collector does not rotate	collector is not moved along by the driver	ensure precise guidance in the driver
Momentary-contact limit switch not actuated	the holding ring on upper bend is not tight enough – as a result it is lifted up by the water pressure	tighten the holding ring halves
Abnormal motor or gearbox noise	low oil level oil worn defective bearing	top up oil exchange the oil exchange bearing
System does not start up	<ul style="list-style-type: none"> • main switch turned off • safety disconnect Q1 turned off • fuses of fuse switch disconnecter defective • fuses F1, F2, F3, F4 defective • safety circuit interrupted because system flex larger than maximum permissible bending angle • no water pressure (<i>only with low-pressure shut-off option</i>) • power supply oscillator box interrupted 	turn it on turn it on replace defective fuses replace defective fuses see “Restart after doglegging” check water supply readjust pressure switch check, recharge battery if necessary



A certain tower always runs in the safety circuit	Wrong micro-switch setting in the tower box micro-switch defective contactor defective cable loose tower slips thermal protection (<i>installed in the motor</i>) triggered because of: obstacle in the track deep soil low oil in gearbox	readjust the micro-switch replace the micro-switch replace the contactor check connections and tighten, if required level the track remove obstacle fill up and level the track refill oil
Main cart differs in distance to cable or furrow guidance when running forward or backwards.	micro-switches of the linear control adjusted differently steering antennas wrongly adjusted (see chapter 12)	readjust both micro-switches in both linear controls and make sure they match adjust antennas according to Operating- / Mounting Instructions

21.1 RESTART AFTER DOGLEGGING WITH TOWER ALIGNMENT SWITCH



NOTE!

Before you follow the instructions below, the cause that led to doglegging must be located and eliminated (see *Troubleshooting*).



1. Turn "SAFETY CIRCUIT" switch to "OFF".



WARNING!

In the "OFF" position, the "SAFETY CIRCUIT" switch deactivates the safety system. This position is allowed for service jobs only.

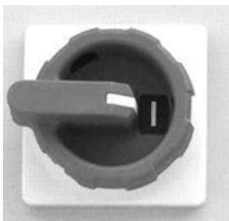

2. Turn main switch to "1".



3. Turn "CLE PRO ON-OFF" switch to "ON".

4. "SETUP" will be displayed on the control panel.
5. Press key "F" (*FORWARD*) and/or "R" (*REVERSE*) for the required travelling direction. Pay attention to the pick-up noise of the respective contactor in the control cabinet.
6. Return the "doglegging" towers into a straight line with the other towers and the pivot again with the help of the tower alignment switch (*below every alignment control*).



7. Turn the "SAFETY CIRCUIT" switch to "ON".

8. Control the correct start of the CENTERLINER by testing the start. Press key "F" or "R" on the control panel.



21.2 RESTART AFTER DOGLEGGING WITHOUT TOWER ALIGNMENT SWITCH



1. Turn the "SAFETY CIRCUIT" switch to "OFF".



WARNING!

In "OFF" position, the "SAFETY CIRCUIT" switch deactivates the safety system.

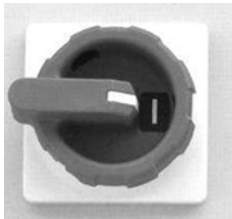

2. Turn main switch to "1".



3. Turn switch "CLE PRO" to "ON".

4. "SETUP" will be displayed on the control panel.
5. Press key "F" (*FORWARD*) and/or "R" (*REVERSE*) for the required travelling direction. Pay attention to the pick-up noise of the respective contactor in the control cabinet.

Keep the "-" button pressed on the control panel in order to move the end tower to the defined travelling direction.

Keep the "+" button pressed on the control panel in order to move the main cart to the defined travelling direction.

Select that travelling direction that brings the outermost spans into a straight line with the system. This means, if the outer, doglegged spans are pointing "FORWARD", you have to select the "REVERSE" travelling direction on the control panel. If the outer doglegged spans are pointing in "REVERSE" direction, you have to select the "FORWARD" travelling direction.

Then move the end tower and/or the main cart as described above until the doglegged spans have been aligned. Check the travelling direction when starting the spans. If the travelling direction was wrong, release the key immediately.



WARNING!

Selecting the proper travel direction ensures that only the outer misaligned towers start moving when the drive is turned on.

The wrong travelling direction will cause impermissibly high stresses on the trussing.



NOTE !

The towers only run as long as you hold the "-" and/or "+" button depressed.

NOTE !

The inward towers may start running for a short time after the start-up

WARNING!

Continuously check tower movement after the start in order to be able to stop the system again immediately should the doglegging continue (*Let go the "-" and/or "+" button*).



6. Turn the "SAFETY CIRCUIT" switch to "ON".

NOTE!

Running BAUER CENTERLINER with "SAFETY CIRCUIT OFF" is only permitted for system alignment.

7. Check proper CENTERLINER start-up by a test start. The green lamp "Safety OK" will be lit when the system is operating correctly.

22 TECHNICAL DATA

22.1 DIMENSIONS OF CENTERLINER 9000

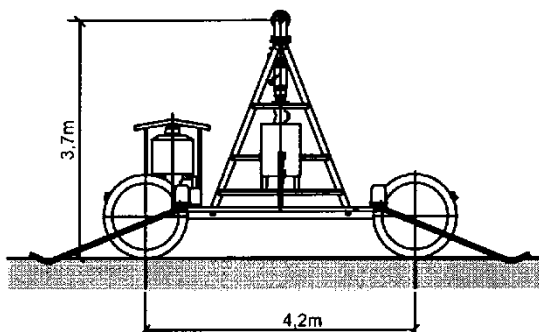
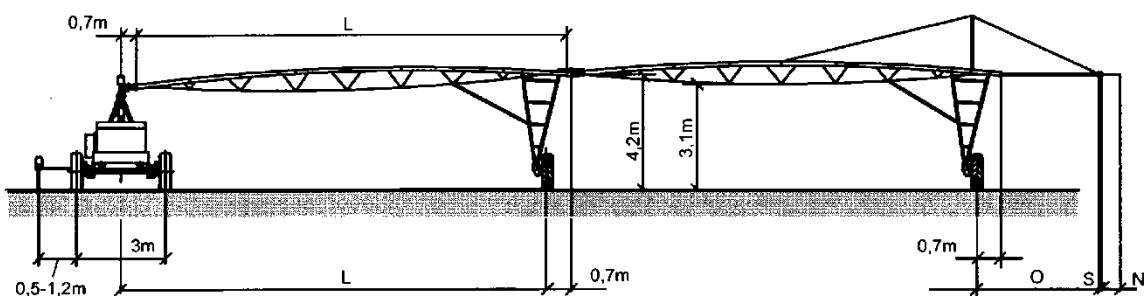

Span		59,8	54,0	48,1	42,3	36,4
Span						
Länge	L m	59,80	53,95	48,10	42,25	36,40
Longueur						

Überhang		23,4	17,6	11,7	5,9	0
Überhang						
Porte-a-faux	O m	24,1	18,3	12,4	6,6	0,7
Länge						
Longueur						
Sandfang	S m	0,15	0,15	0,15	0,15	0,15
Sand trap						
Dessableur						
Sprühboisverlängerung	N m	1,2	1,2	1,2	1,2	1,2
Spray nozzle extension						
Rayonage de buse atomiseur		3,0	3,0	3,0	3,0	3,0



22.2 GEARBOX AND DRIVE MOTORS

22.2.1 GEARBOX

Worm gear with 50:1 reduction ratio.
Execution: For stationary systems.
For towable systems with freely rotating hub.

Type of oil: SAE 85W-140, multigrade oil
Oil quantity approx. 3.8 litres up to lower edge of filling hole
Oil expansion is compensated by expansion membrane.

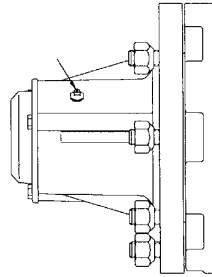
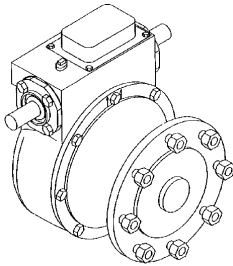

22.2.2 DRIVE MOTOR

Spur gearing with 40:1 reduction ratio optional 30:1 reduction.
Standard motor output: 0.55 kW optional 1.1 kW

Driving speed with tires 14.9-24 reduction 40:1 = 144 m/h
reduction 30:1 = 193 m/h

Type of oil: SAE 50W or SAE 20W-50 multigrade motor oil
Amount of oil approx. 3.8 litres up to lower edge of filling hole

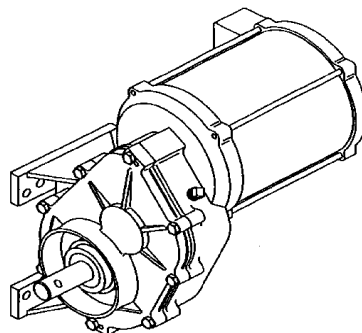

23 OPTIONS

23.1 Low pressure shut-off

The supply pressure on the drive cart is monitored by a pressure gauge. If the supply pressure is lower than the minimum pressure set on the pressure gauge, the shut-off valve closes (*option*), and the Centerliner shuts down.

WARNING	Set a precipitation rate of >0 mm on the control panel in order to activate the <i>low pressure shut-off!</i>
----------------	---

With a set precipitation rate of 0 mm, the machine can run without irrigating (*dry*). (e.g. if CENTERLINER is to be moved to the parking position due to natural rainfall)

23.2 ELECTRIC SHUT-OFF VALVE (MAIN CART)

An electric shut-off valve in the main cart infeed line is closed automatically, if the CENTERLINER is shut off or due to a malfunction.

23.3 END GUN

To increase the irrigated strip width or the system's spraying radius in the swivelling area, an end gun can be mounted at the end of the CENTERLINER overhang. It can operate both along the whole irrigation strip or only along parts of it.

If you want to have an interrupted gun operation, an automatic "ON/OFF" control should be set.

23.4 BOOSTER PUMP FOR END GUN.

In most cases a higher pressure is required for the end gun than for the regular nozzeling of the CENTERLINER. An electric booster pump, which is mounted on end tower, provides the sufficient operating pressure for the end gun. A pressure hose connects the pump on the last tower with the gun on the overhang.

23.5 AUTOMATIC "ON/OFF" CONTROL FOR THE END GUN / PUMP

Along the irrigation strip, the end gun or the booster pump can be switched on and off in sectors. The water supply to the end gun is controlled via an electric 2" valve. Along the track on the last tower switching frames are set for the "ON/OFF" switching points of the end gun. On the end tower a switch is mounted (*turn switch*).

At one switching point the end gun resp. the pump is activated, at the next switching point the end gun resp. the pump is shut down again. This switching process can be repeated several times along the irrigation strip.

23.6 AUTOMATIC INTERVAL CONTROL

If the end gun is operated with a big nozzle for a huge spray range, the irrigation would be too high towards the end. For that purpose an automatic interval control is provided, which opens and closes a 2" valve automatically and thus controls the operating time of the end gun. At the TIME/BREAK relay the operating time and break time of end gun can be set.

23.7 AUTOMATIC „ON/OFF' AND INTERVAL CONTROL

This control combines the two above mentioned controls for the end gun and the booster.

23.8 DRIVE TOWER ALIGNMENT SWITCH

This switch is mounted outside on the base plate of the alignment control box. With this switch the individual towers can be moved forward or back without having to open the alignment control box. This feature makes it easy to align the system for the initial start-up and the realignment of towable systems in their new position.

23.9 RUNNING LIGHT

The running light can either be mounted directly to the main cart or to any drive tower or directly to the first trussing just in front of the main cart. The running light is lit as long as the CENTERLINER is in operation.

23.10 END STOP

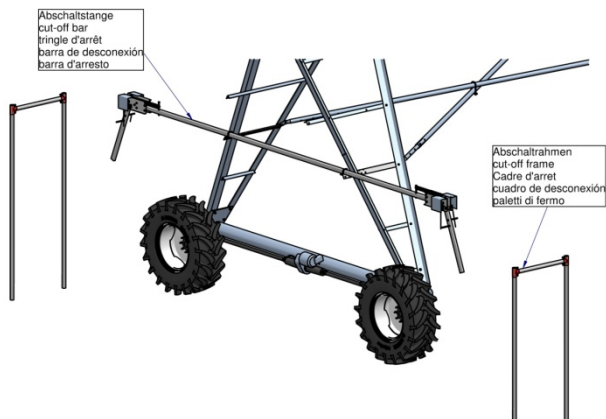

End stop

If the machine needed to be stopped exactly at the sector boundaries, shut-off will be made at the system end. A cut-off bar mounted to the last drive tower is actuated by a cut-off frame mounted in the track. Thus the machine will be stopped precisely at the required sector end.

23.11 STOP RAMP

This ramp serves as an emergency shut-down at the end of the irrigation track. In case every switch-off system fails, the end tower runs against the ramp fixed into the soil and stops the CENTERLINER mechanically. Subsequently, the motor protection switch on the end tower shuts down the system.

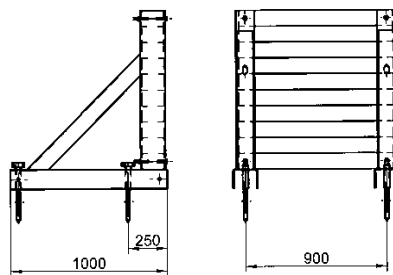

23.12 DOUBLE NOZZELING

CENTERLINER CLX 9000 can also irrigate during the swivelling process (*OUTSWING*, *PIVOTING* mode). Different nozzelings are necessary for the irrigation in *LINEAR* and in *PIVOTING* mode. These are switched over automatically according to the operating mode.

23.13 REPOSITIONING OF CENTERLINER

GENERAL INSTRUCTIONS

- Repositioning is not possible for the Centerliner with below ground guidance.
- System should be moved on a level and preferably on a paved road (*width 7 m*).
- The track must be level and free from ruts, grooves, and furrows.
- If there are ruts in the lane they have to be levelled.
- Repositioning of the system in the field (*off the road*) should be avoided.
- If the system has to be moved in the field, the travelling lane must be levelled first and any obstacles removed in order not to increase the rolling drag.
- Max. "towing speed": 4 km/h
- Tire pressure: 1 – 1.5 bar

23.13.1 TOWING THE CENTERLINER FROM THE MAIN CART

For towing from the main cart, a cable bracing from the main cart to the first drive tower is necessary.

23.13.1.1 SWIVELLING THE TOWER AND MAIN CART WHEELS

- Loosen and push back the drive shaft covers of the gearboxes.
- Loosen the driver on the wheel hub and/or disengage gearboxes with lever.
- Loosen fastening of gearbox support.
- Turn gearbox support and wheel. The coupling parts with the rubber packages have to stay at the gearbox. If necessary lift wheel base with jack or tractor's hydraulic.

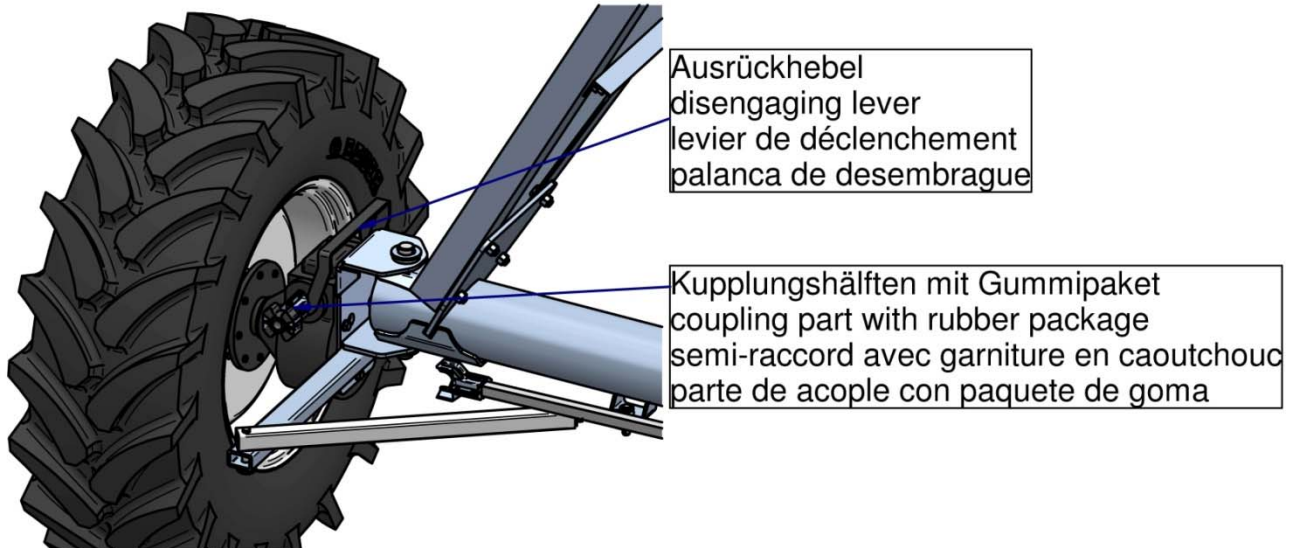

- Deposit the drive shaft with the coupling halves at the fastener that is mounted at the support angles of the drive tower.
- Support of the gearbox with connecting brace (90 ° twisted).

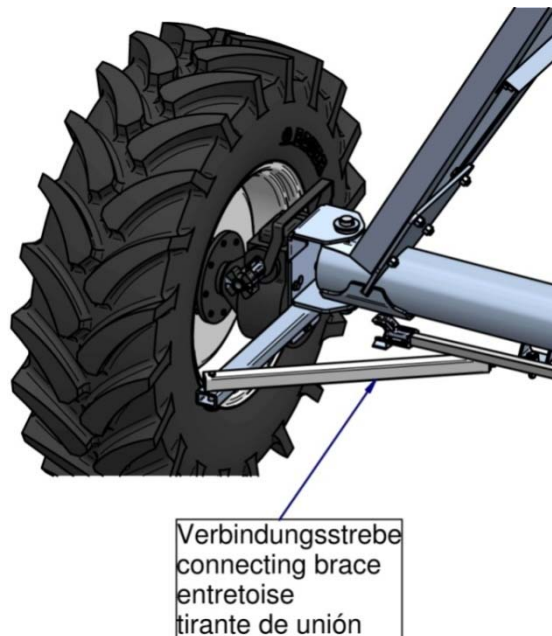

23.13.1.2 MOUNTING THE TOW CABLES ON THE CENTERLINER'S MAIN CART

- Fasten the clamp on the end pipe of the first drive tower.
- Hook up the cables and adjust them (*the first time*):
- Mount the drawbar (*the first time*):

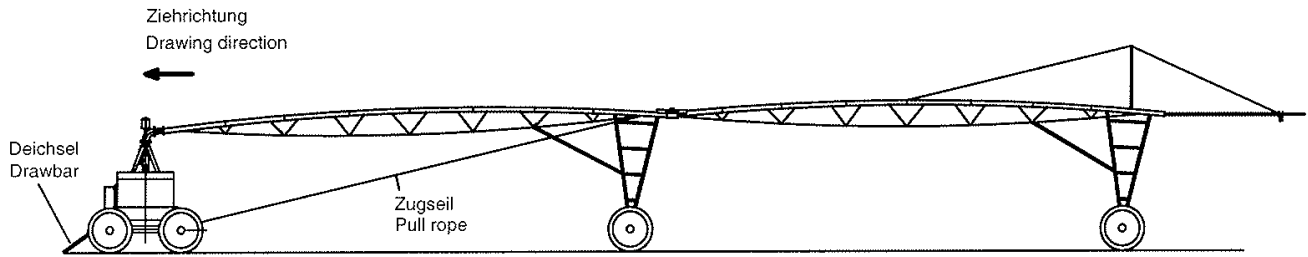



24 ELECTRIC CIRCUIT DIAGRAMS

23.1 CENTERLINER PIVOT PANELS

- 23.1.1 PIVOT PANEL SELECT PRO - IN-FEED
- PIVOT PANEL SELECT PRO - CONTROL
- PIVOT PANEL SELECT PRO - OPTION 1
- PIVOT PANEL SELECT PRO - OPTION 2
- 23.1.2 PIVOT PANEL SELECT PRO - CONNECTION DIAGRAM

23.2 CENTERLINER LINEAR CONTROL UNITS

- 23.2.1 PIVOT PANEL LINEAR CONTROL - FURROW GUIDANCE
- 23.2.2 PIVOT PANEL LINEAR CONTROL - CABLE GUIDANCE
- 23.2.3 PIVOT PANEL LINEAR CONTROL - BELOW GROUND GUIDANCE

23.3 ALIGNMENT CONTROL UNITS

- 23.3.1 ALIGNMENT CONTROL STANDARD
- 23.3.2 ALIGNMENT CONTROL WITH TOWER ALIGNMENT SWITCH
- 23.3.3 ALIGNMENT CONTROL WITH END TOWER MONITORING DEVICE
- 23.3.4 ALIGNMENT CONTROL WITH TOWER ALIGNMENT SWITCH AND E.T. MONITORING DEVICE
- 23.3.5 ALIGNMENT CONTROL WITH TOWER ALIGNMENT SWITCH FOR ELECTRIC SWIVELLING OF DRIVE TOWER WHEELS
- 23.3.6 ALIGNMENT CONTROL WITH TOWER ALIGNMENT SWITCH AND E.T. MONITORING DEVICE FOR ELECTRIC SWIVELLING OF DRIVE TOWER WHEELS
- 23.3.7 END CONTROL STANDARD
- 23.3.8 END CONTROL WITH TOWER ALIGNMENT SWITCH
- 23.3.9 END CONTROL WITH END STOP
- 23.3.10 END CONTROL WITH END STOP AND TOWER ALIGNMENT SWITCH
- 23.3.11 END CONTROL STANDARD WITH END STOP AND AUTOREVERSE
- 23.3.12 END CONTROL DRIVE TOWER ALIGNMENT SWITCH WITH END STOP AND AUTOREVERSE
- 23.3.13 END CONTROL DRIVE TOWER ALIGNMENT SWITCH FOR ELECTRIC SWIVELLING OF DRIVE TOWER WHEELS

23.4 BOOSTER PUMP FOR END GUN

24.1 CENTERLINER PIVOT PANELS

24.1.1 PIVOT PANEL SELECT PRO - IN-FEED

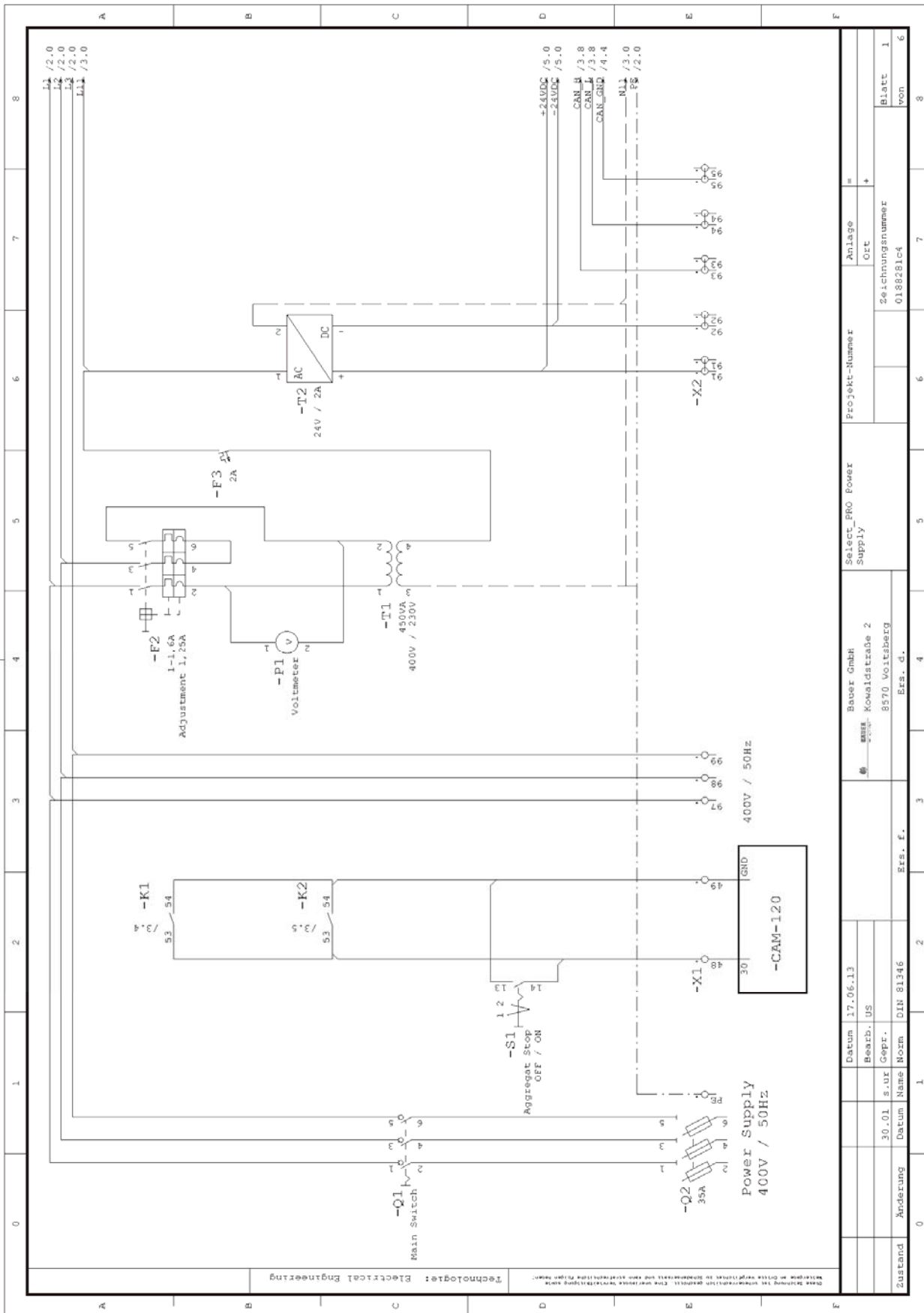

Zustand		Änderung		Datum	17.06.13	Bauer GmbH		Projekt-Nummer		Anlage	
30.01.s.ux		Gepr.		Baujahr		Baujahr		01.88281c4		Ort	
DIN 81346		Ers. F.		Ers. d.		8570 Voitsberg		26.1		Zählungsnummer	
Blatt 1		von		6		8		6		7	

PIVOT PANEL SELECT PRO - CONTROL

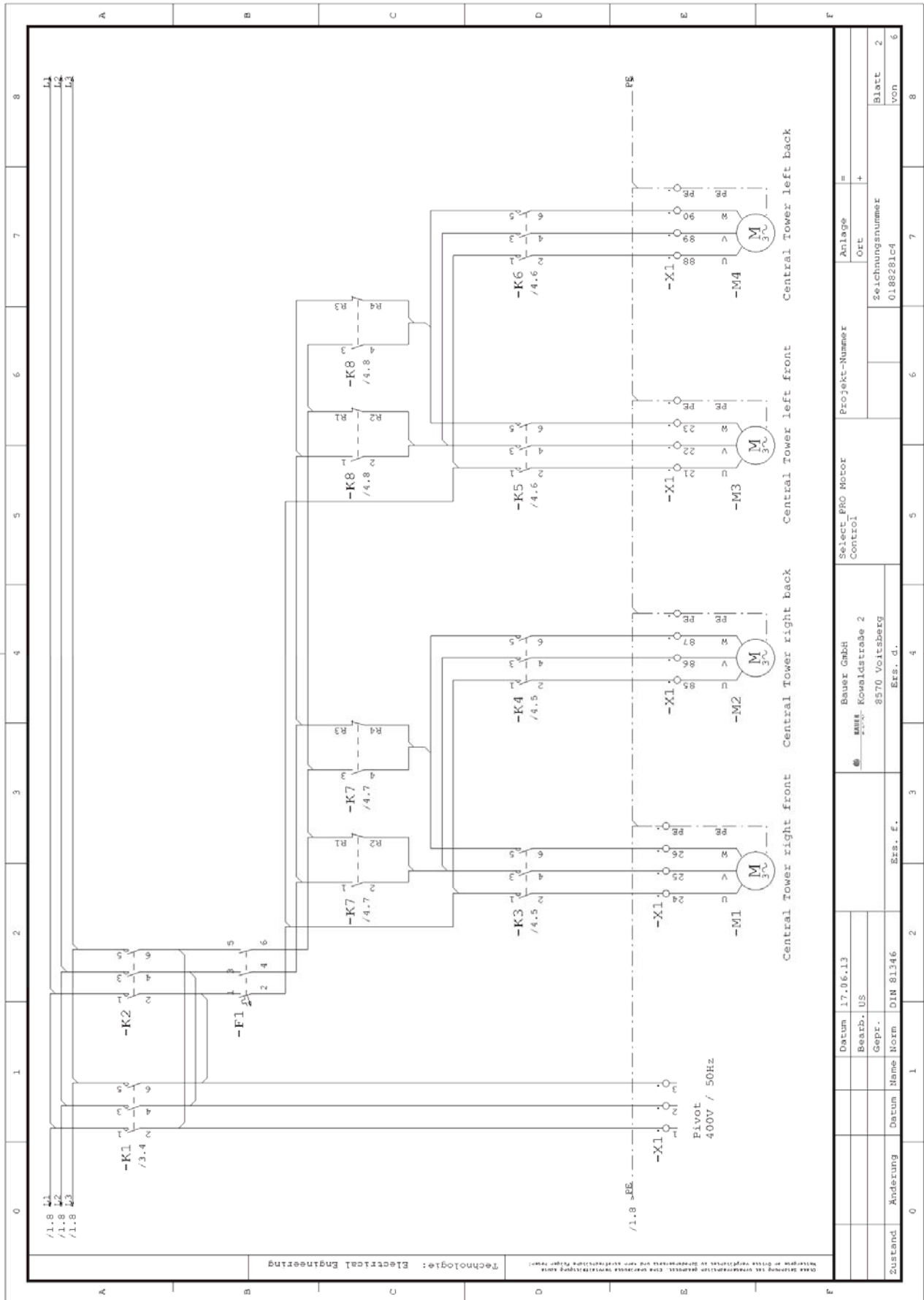

Zustand	Änderung	Datum	Name	Norm	DIN 81346	ES. E.	ES. d.	8570 Voitsberg	8570 Voitsberg	Bauer GmbH	Select PRO Motor Control	Projekt-Nummer	Anlage	Ort	Blatt	von
		17.06.13	US					Kowaldstraße 2							2	6
															2	6

PIVOT PANEL SELECT PRO - CONTROL

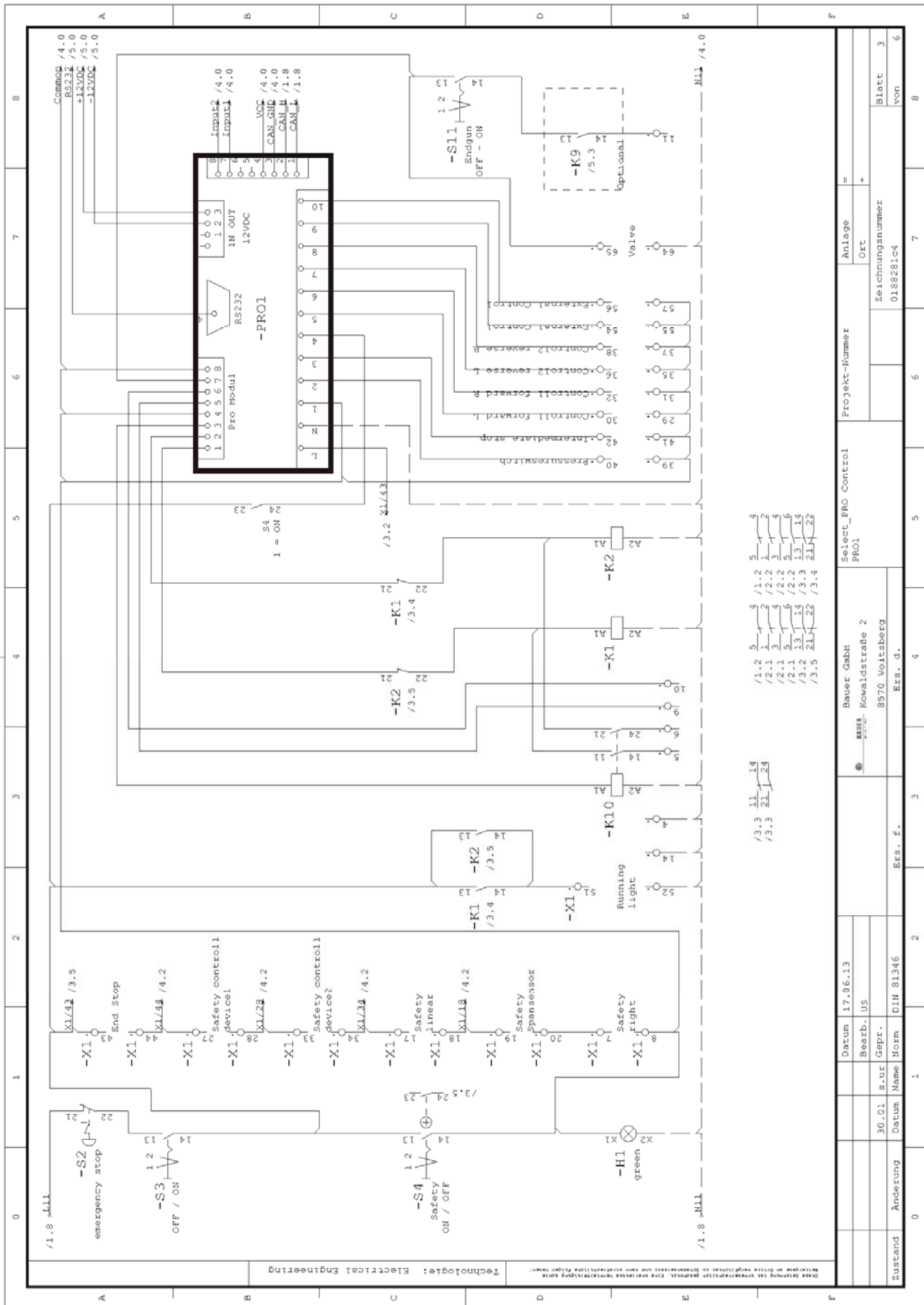



PIVOT PANEL SELECT PRO - CONTROL

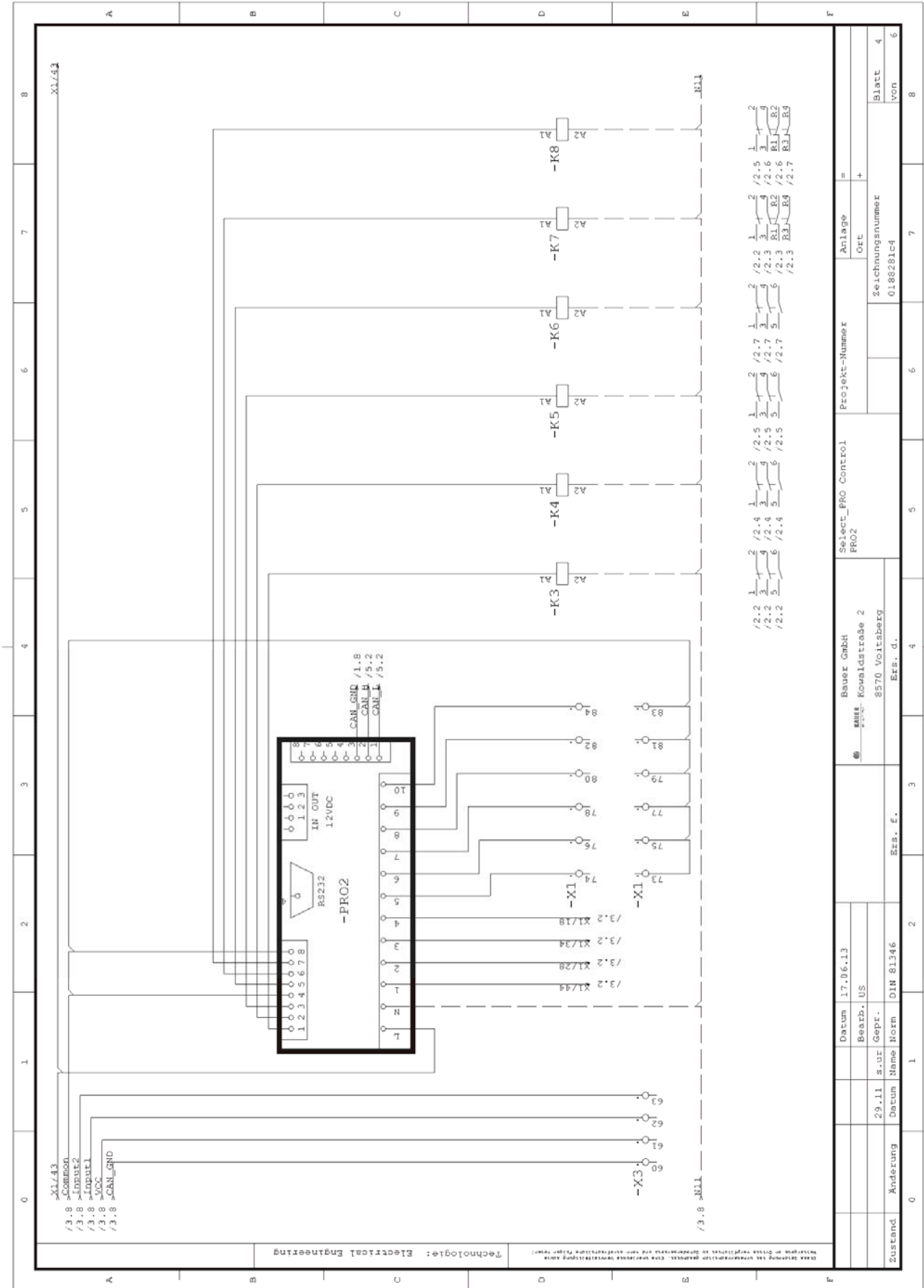

PIVOT PANEL SELECT PRO - OPTION 1

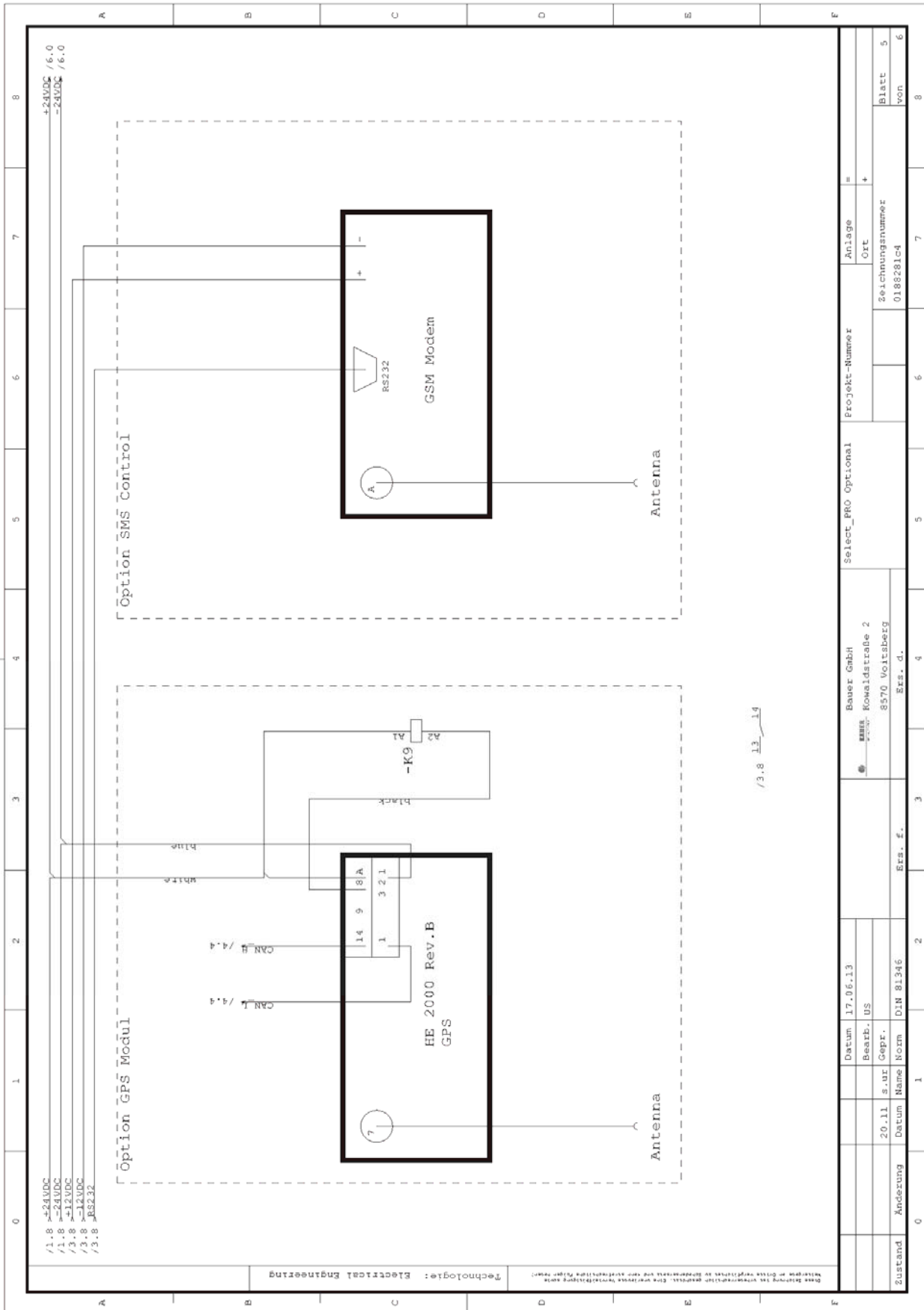

PIVOT PANEL SELECT PRO - OPTION 2

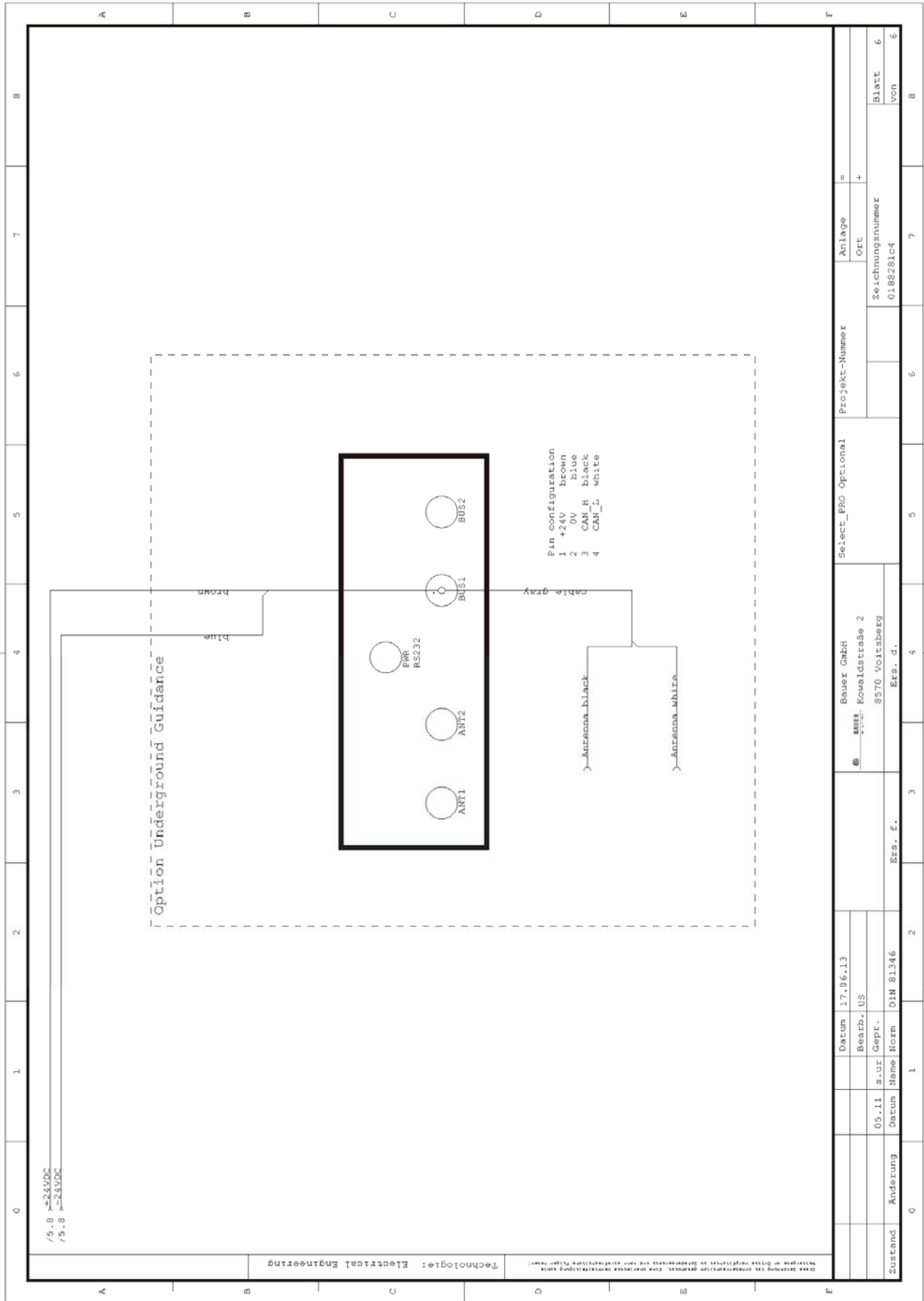

Zustand		Änderung		Datum	Name	Norm	Ers. f.		Ers. d.		
				05.11	s.ur	Gepr.	DIN 81346				
Datei		17.06.13		Bauer GmbH		Kavalidstraße 2		8570 Veitsberg		Ers. d.	
Projekt-Nummer		Anlage		Ort		Zeichnungsnummer		Blatt		von	
						0186281c4		6		8	

24.2 PIVOT PANEL SELECT PRO - CONNECTION DIAGRAM 1

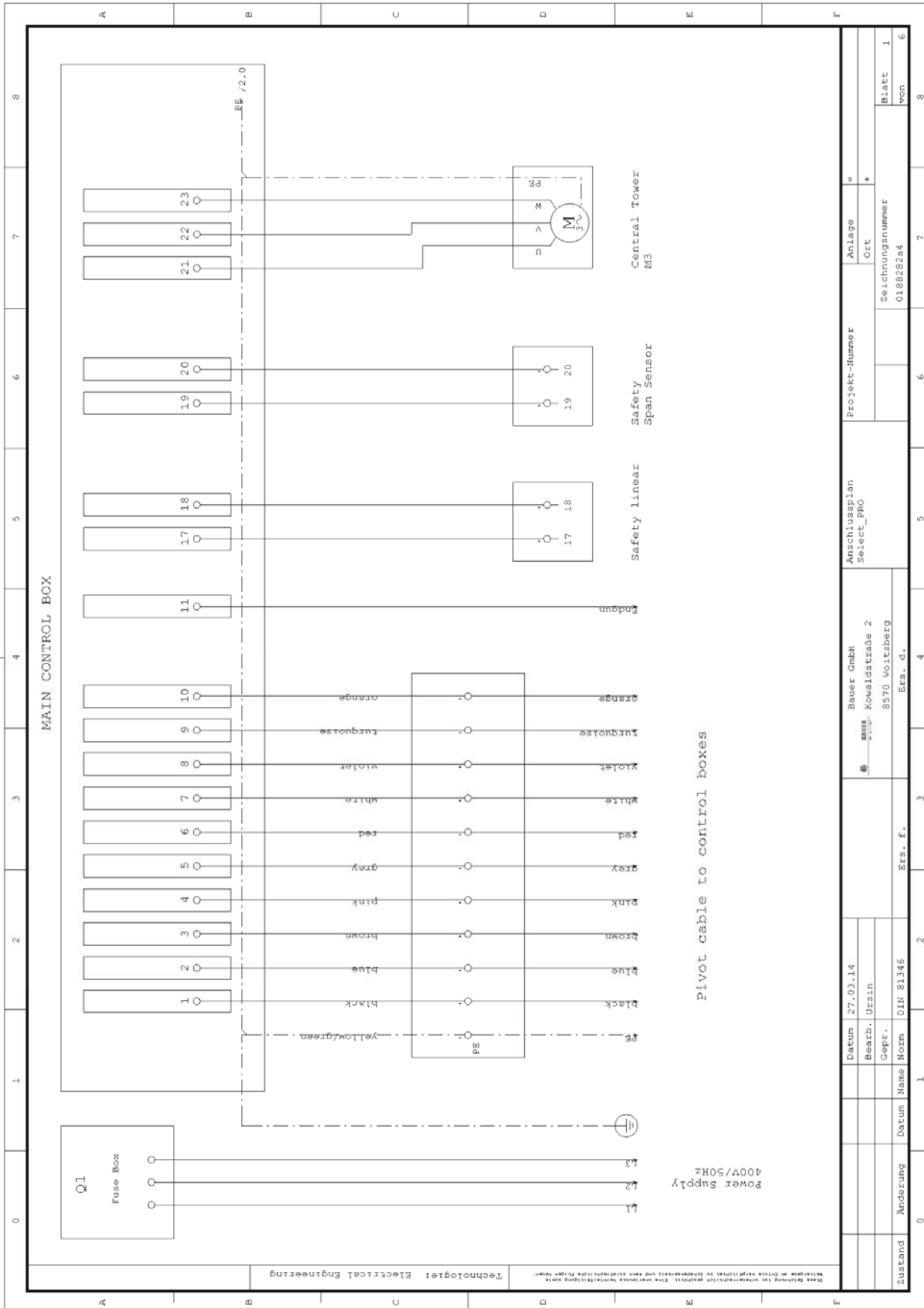

Zustand	Anderung	Datum	Name	Norm.	DIN 81346	EES. f.	
		Datum	27.03.14				
		Bearb.	Ufsin				
					Bauer GmbH		
					Kowaldstraße 2		
					8570 Voitsberg		
					EES. d.		
		Anschlussplan		Projekt-Nummer		Anlage	
		Select_PRO				Ort	
						Zeichnungsnummer	
						Blatt	
						von	
						1	
						6	



PIVOT PANEL SELECT PRO - CONNECTION DIAGRAM 2

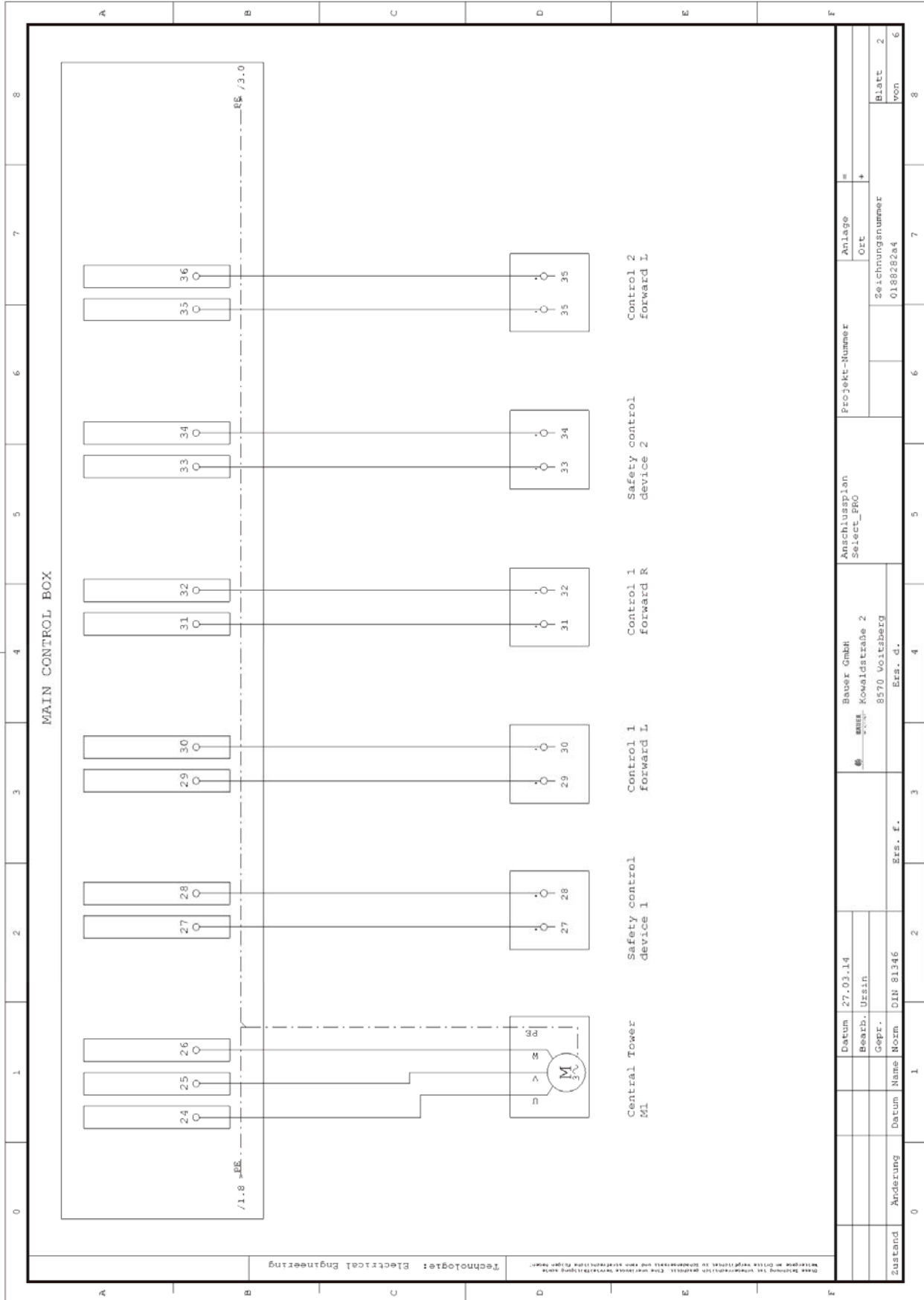

PIVOT PANEL SELECT PRO - CONNECTION DIAGRAM 3

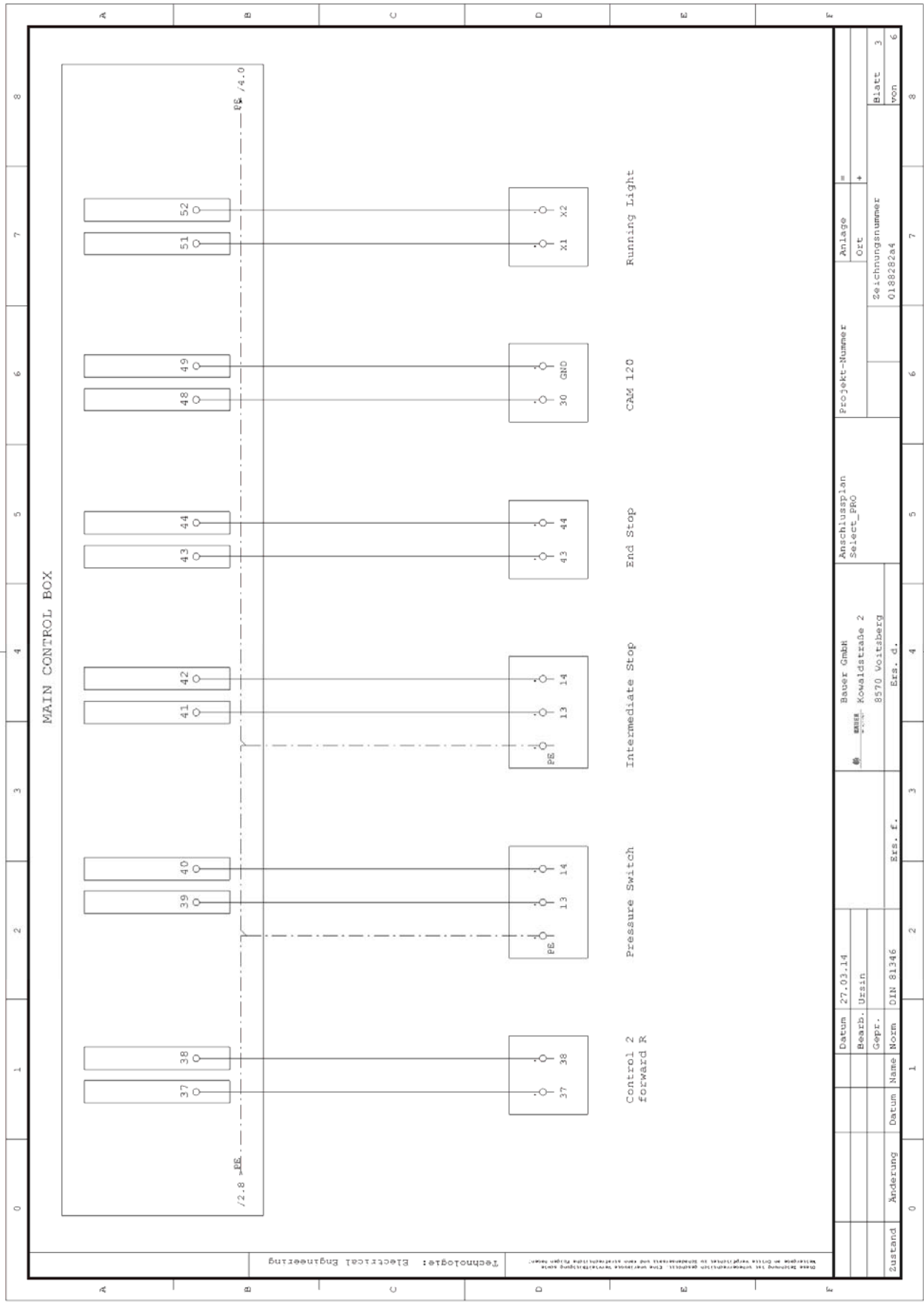



PIVOT PANEL SELECT PRO - CONNECTION DIAGRAM 4

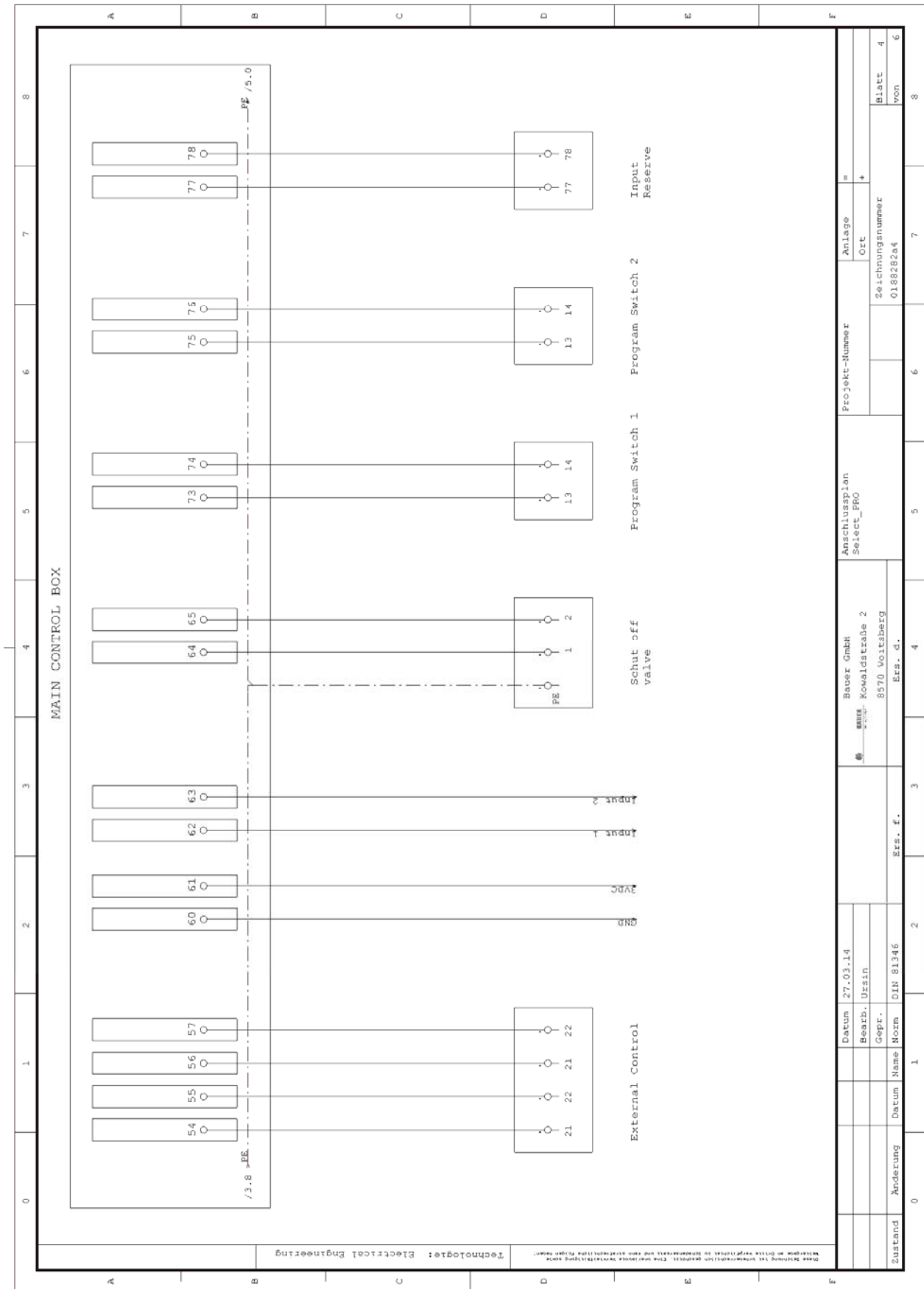

PIVOT PANEL SELECT PRO - CONNECTION DIAGRAM 5

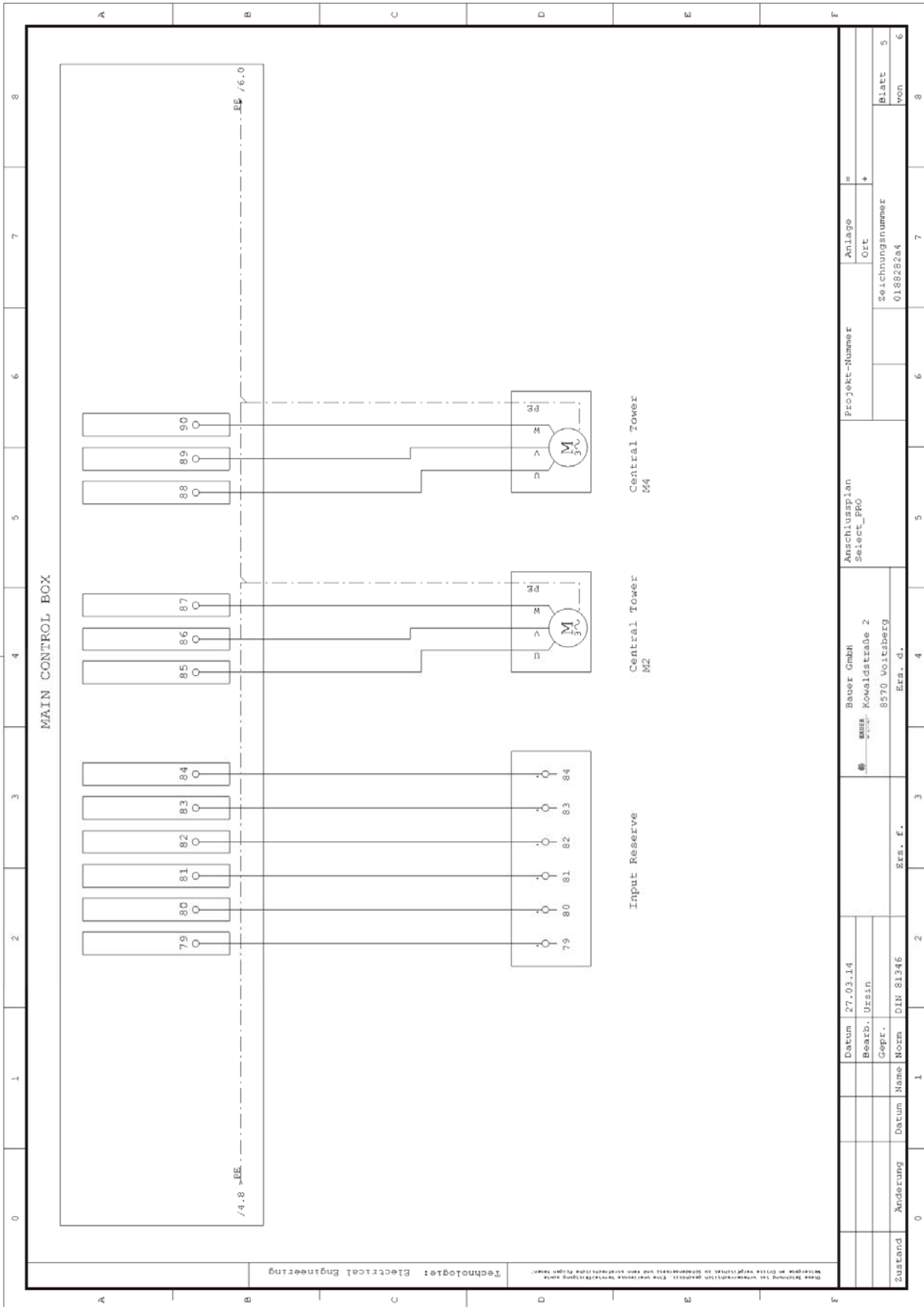

PIVOT PANEL SELECT PRO - CONNECTION DIAGRAM 6

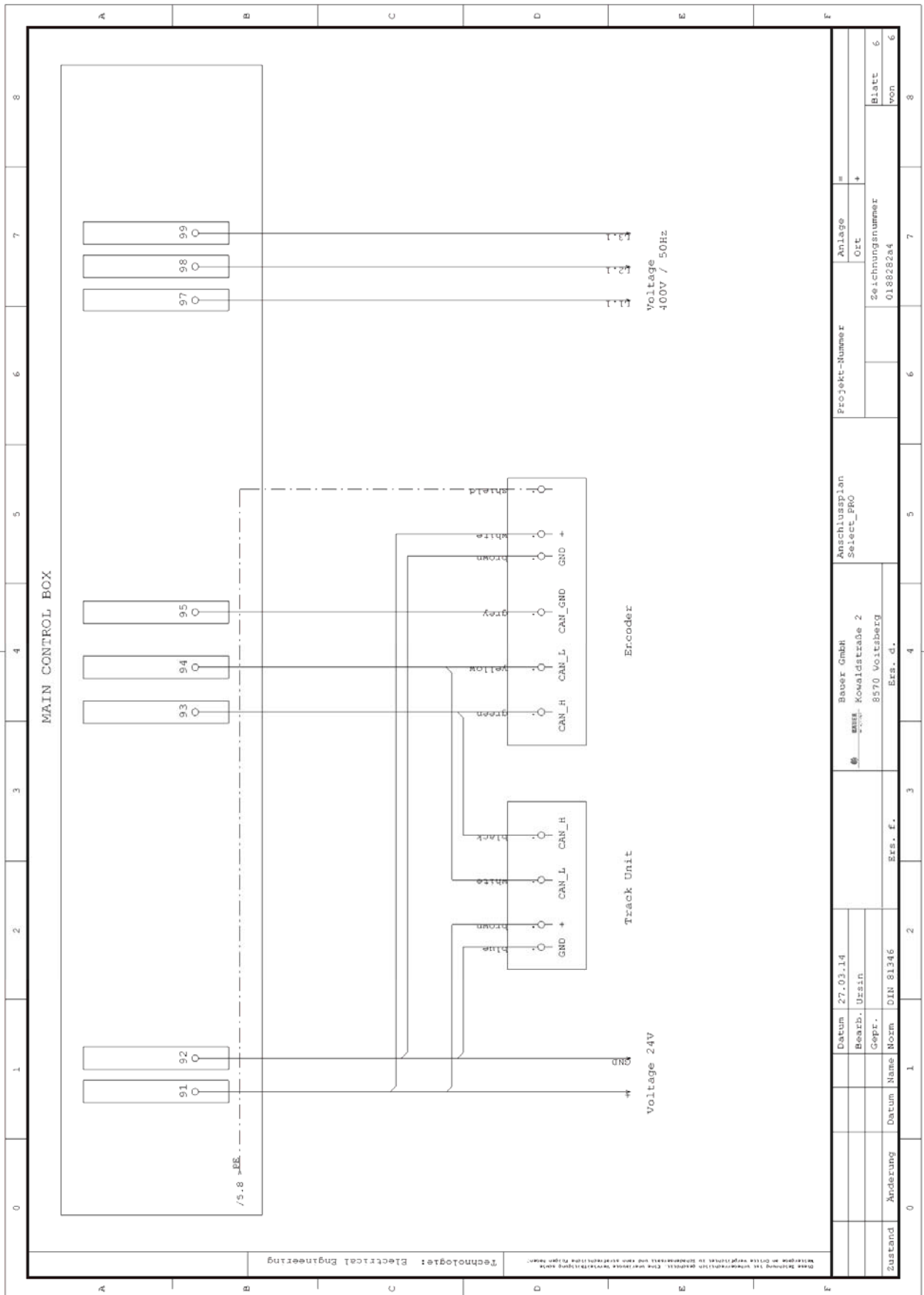

24.3 CENTERLINER LINEAR CONTROL UNITS

24.3.1 CENTERLINER LINEAR CONTROL - FURROW GUIDANCE

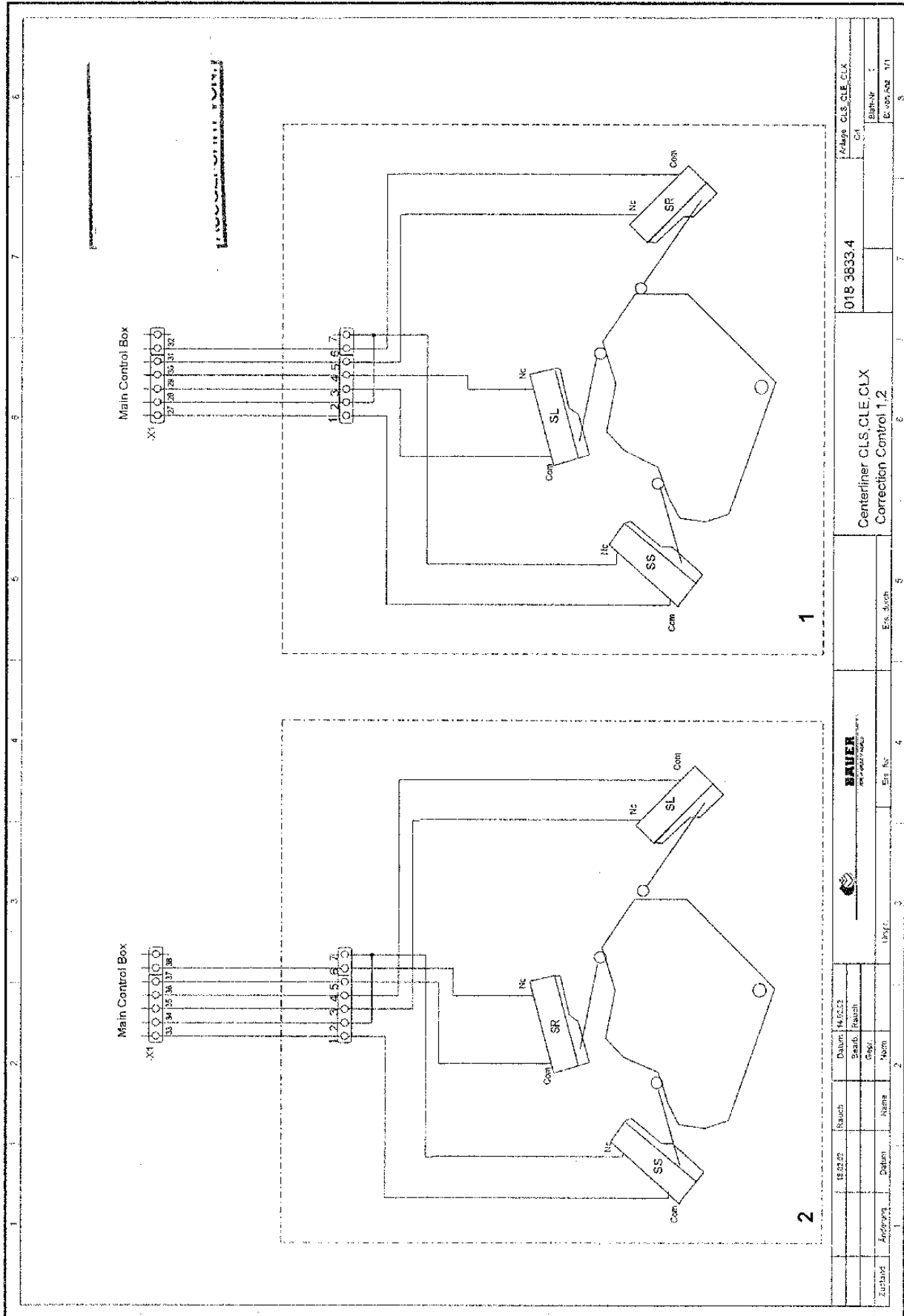

24.3.2 CENTERLINER LINEAR CONTROL - CABLE GUIDANCE

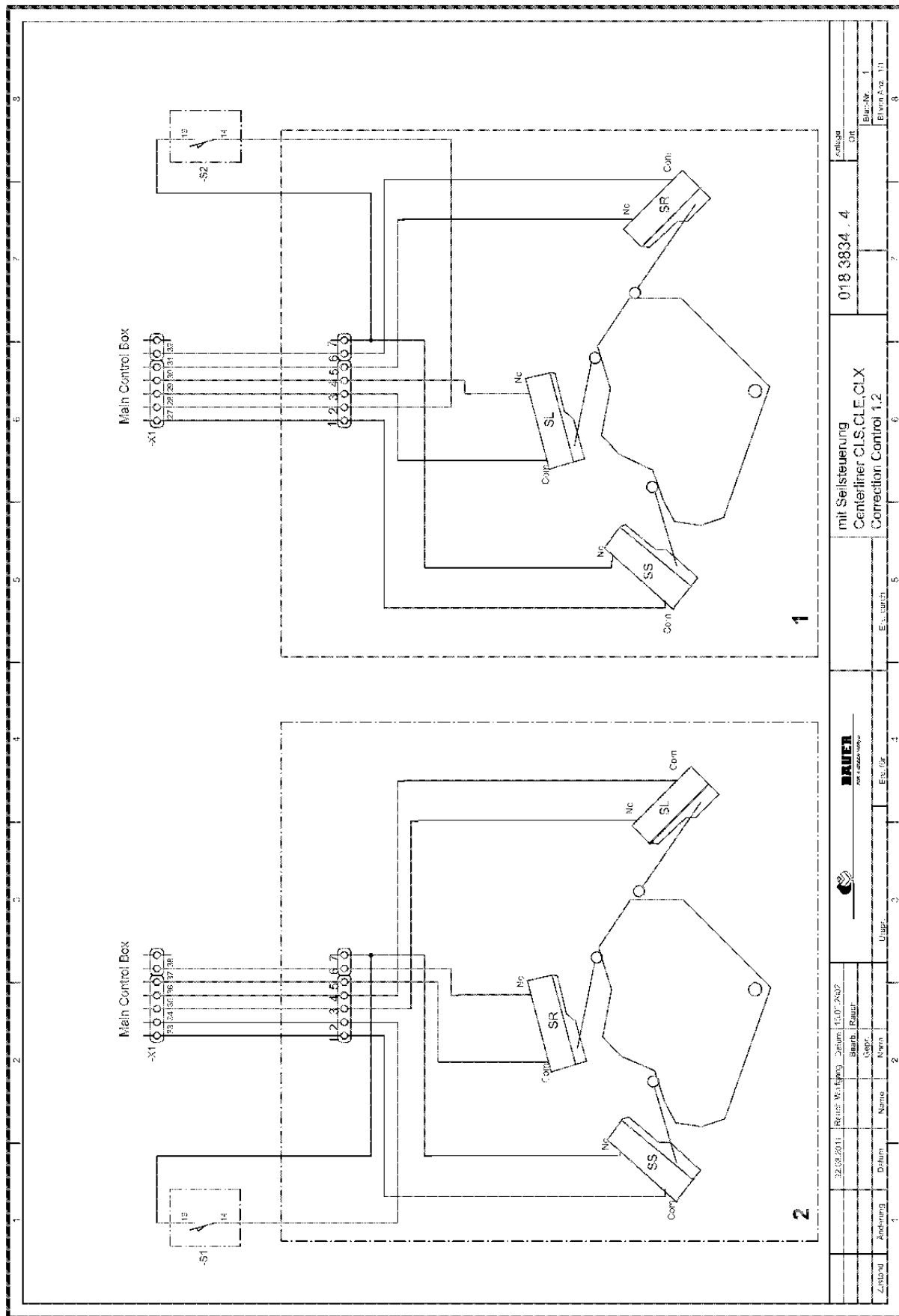

Zuständ	Änderung	Datum	Nr.	Uzger.	3	E Nr. für	4	E Nr. für	5	mit Seilsteuerung Centerliner CLS, CLE, CLX Correction Control 1.2		6	018 3834 . 4	anlag	018	7	
		Blatt-Nr	1							Blatt-Nr	1			Blatt-Nr	1		Blatt-Nr
														8			8

24.3.3 CENTERLINER LINEAR CONTROL UNIT - BELOW GROUND GUIDANCE

24.3.3.1 BELOW GROUND GUIDANCE - TRACK UNIT CONTROL

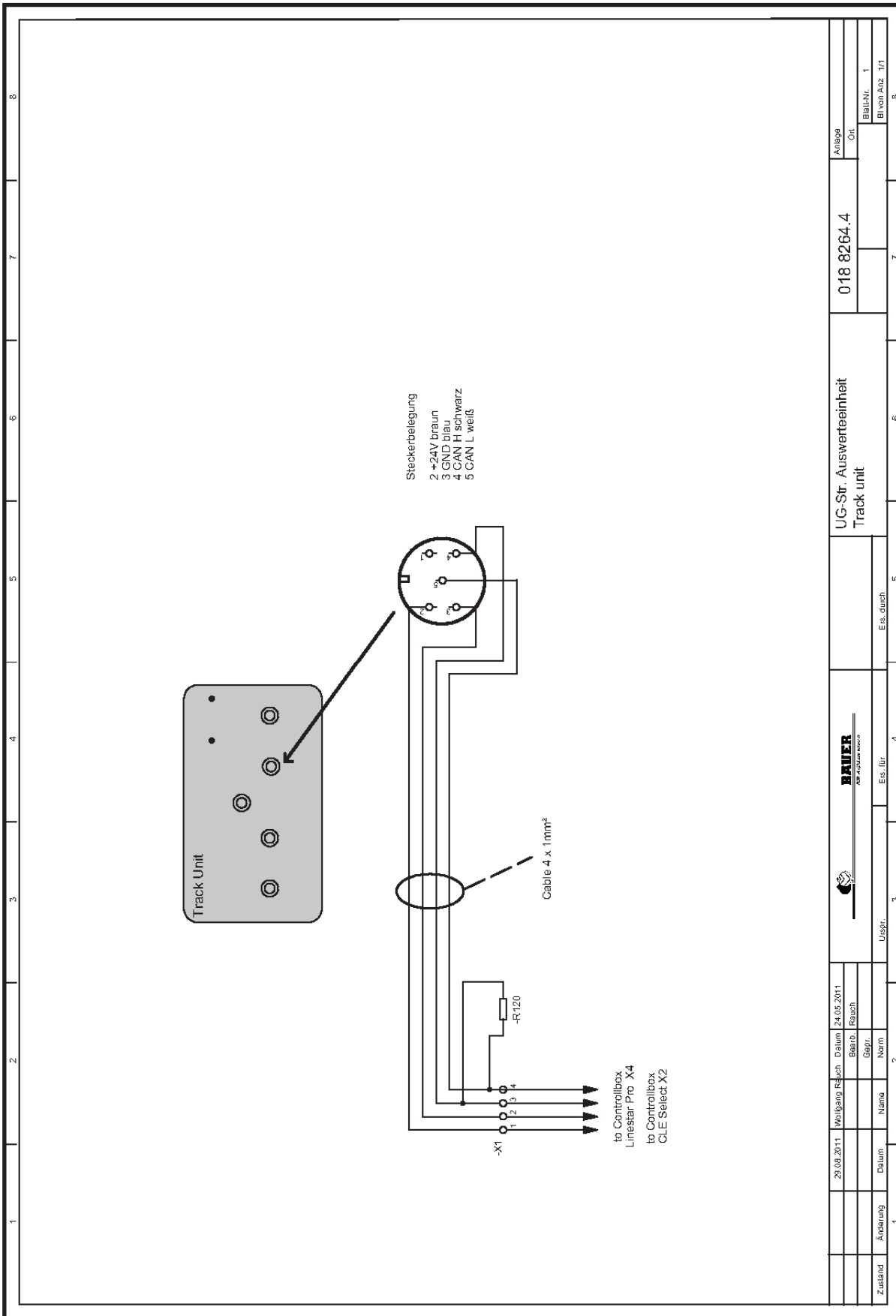

24.3.3.2 BELOW GROUND GUIDANCE - TRACK UNIT CONNECTION DIAGRAM

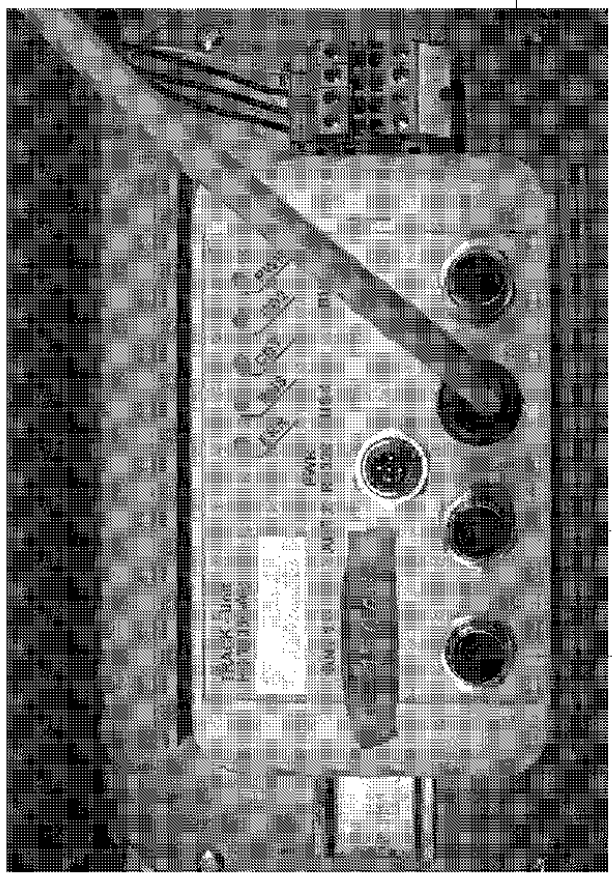

a

a b

zu Schaltschrank Linestar Pro X4 /
zu Schaltschrank Select X2
to Control Unit Linestar Pro X4 /
to Control Unit CLE Select X2

a zu 087 9630 Lenkantenne vorwärts
to 087 9630 forward antenna
zu 087 9630 Lenkantenne rückwärts
to 087 9630 backward antenna

Diese Zeichnung ist unser geistiges Eigentum. Sie darf ohne unser Einverständnis weder kopiert noch Dritten zur Verfügung gestellt oder anderweitig in irgendeiner Weise veröffentlicht werden.		This drawing is our intellectual property and may not be copied, reproduced, distributed, or otherwise disclosed in any way without our written consent.	
Werkstückdaten nach DIN 6784 γ -0.5		Maße:	
Feinmaßstab: nach DIN 7168 nach ISO 13820 fein <input type="radio"/> A <input type="radio"/> B <input type="radio"/> C mittel <input type="radio"/> D <input type="radio"/> E <input type="radio"/> F grob <input type="radio"/> G <input type="radio"/> H <input type="radio"/> I sehr grob <input type="radio"/> J <input type="radio"/> K <input type="radio"/> L		Maßstab:	
Oberflächennennungen:		Halbzug:	
Datum:		Werkstoff:	
Name:		Artikel-Nr.:	
Zeichnungs-Nr.:		Hohlloch-Nr.:	
Rev. / Änderung Datum Name:		Renennung:	
a 15386 110524 Gspul Zust. Änderung Datum Name:		Anschlagplan Auswertereinheit Type: Untergrundsteuerung Zeichnungs-Nr.: 018 8257.3	
b Austausch 110525 Quacht Zust. Änderung Datum Name:		Rohren- u. Pumpenwerk BAUER Ges.m.b.H. 8570 Volsberg, Austria	
Ers. für:		Ers. durch:	

24.3.3.3 BELOW GROUND GUIDANCE - TRACK UNIT PIN ASSIGNMENT

Belegung Stecker
male connector (b)

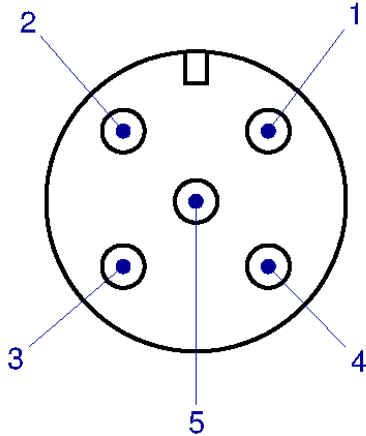

Belegung Buchse
(b) female connector

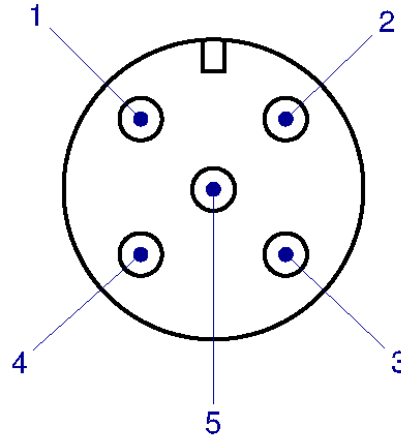

CAN-BUS Pin-Belegung

Pin	Signal
0	Nc
1	+24V
2	GND
3	CAN_H
4	CAN_L

Pin - Stecker/Buchse	Ader Nr. - Kabel 087 0179
0	-
1	1
2	2
3	3
4	4

(a)

(a)

Werkstückkanten nach DIN 6784 $\sqrt{0,5}$

Diese Zeichnung ist unser geistiges Eigentum. Sie darf ohne unser Einverständnis weder kopiert noch dritten Personen ausgehändigt oder anderweitig mißbräuchlich verwendet werden.		This drawing is our intellectual property and must not, without our permission, give away to third parties or misused otherwise.		Paßmaß	Abmaß
Freimaßtoleranz		Oberfläche:	Maßstab:	Masse:	
nach DIN 7168		<input checked="" type="checkbox"/> (✓)	Halzeug: Werkstoff: Artikel-Nr.: Rohteil-Nr.:		
nach ISO 13920					
fein	<input type="radio"/> A				
mittel	<input type="radio"/> B				
grob	<input type="radio"/> C				
sehr grob	<input type="radio"/> D				
Datum		Name		Benennung:	
Gez. 100406		Quach		Montage Steuerkabel	
Gepr.				Type: Untergrundsteuerung	
DXF				Zeichnungs-Nr.: 851 8490.4	
Röhren- u. Pumpenwerk		BAUER		Ers. für:	
Ges.m.b.H.		8570 Voitsberg, Austria		Ers. durch:	
b	Austausch	130909	Quach		
a	16 366	110530	Quach		
Zust.	Änderung	Datum	Name		

24.3.3.4 BELOW GROUND GUIDANCE – OSCILLATOR BOX WIRING DIAGRAM

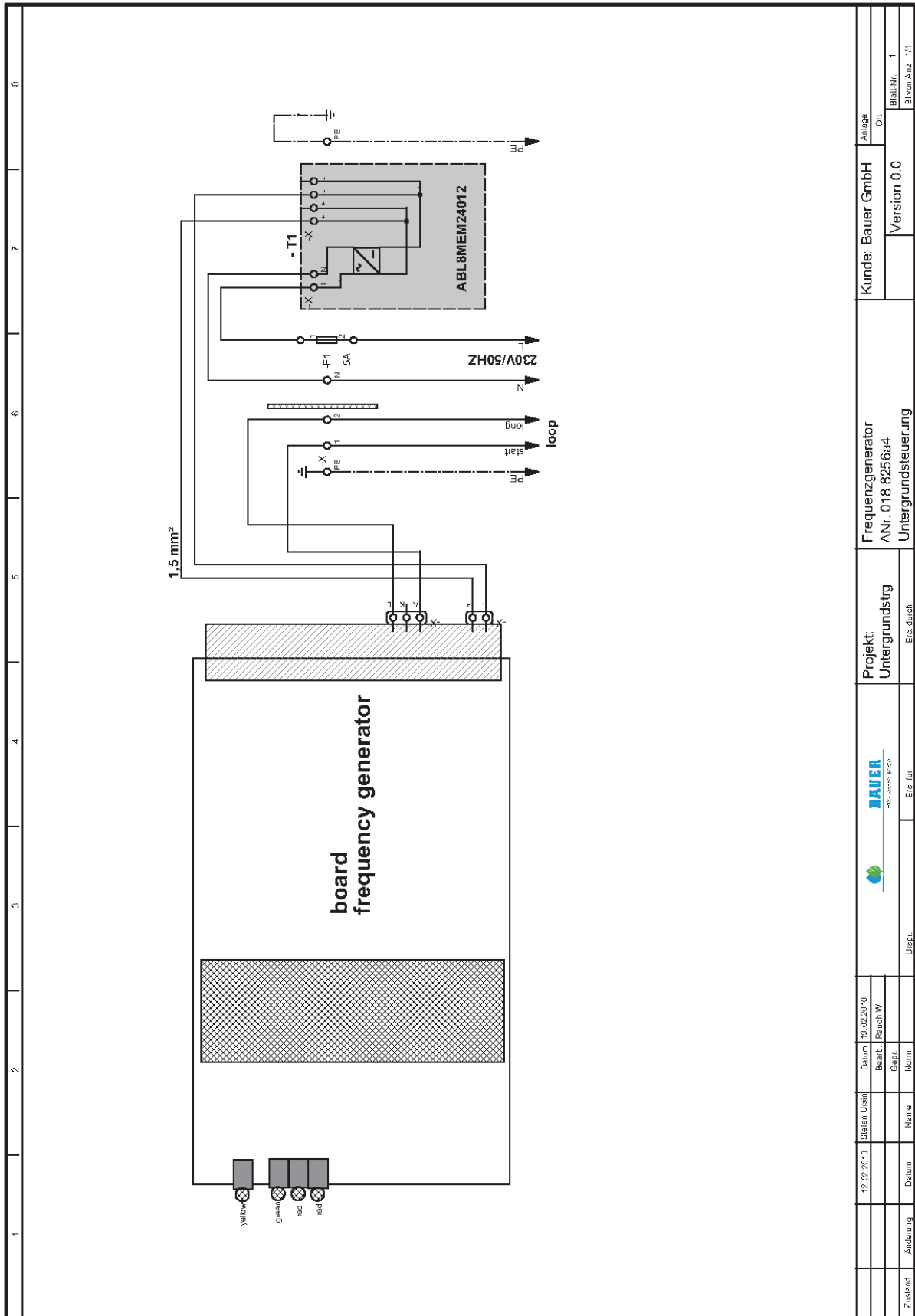

24.4 ALIGNMENT CONTROL UNITS

24.4.1 ALIGNMENT CONTROL STANDARD

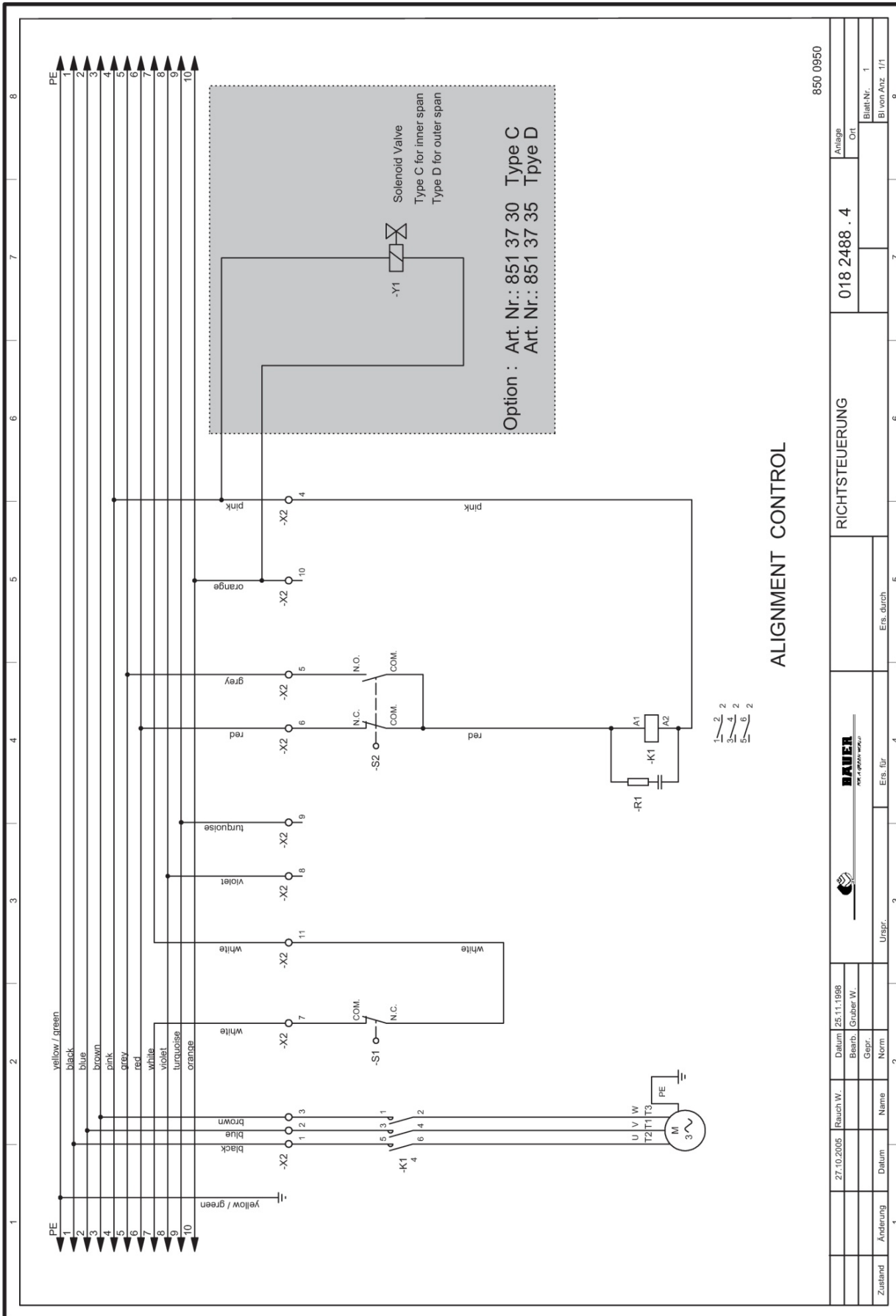



24.4.2 ALIGNMENT CONTROL WITH TOWER ALIGNMENT SWITCH

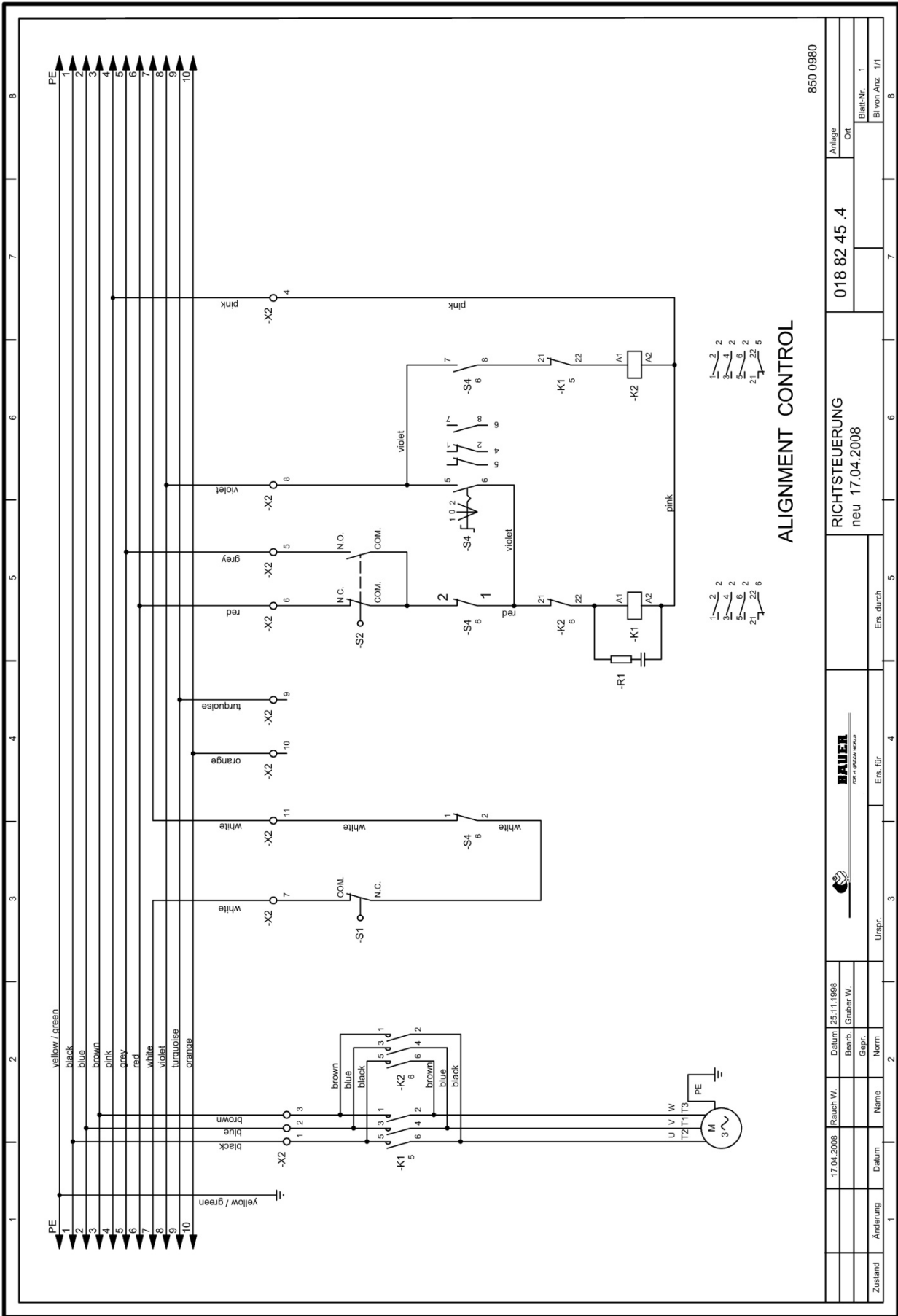

24.4.3 ALIGNMENT CONTROL WITH END TOWER MONITORING DEVICE

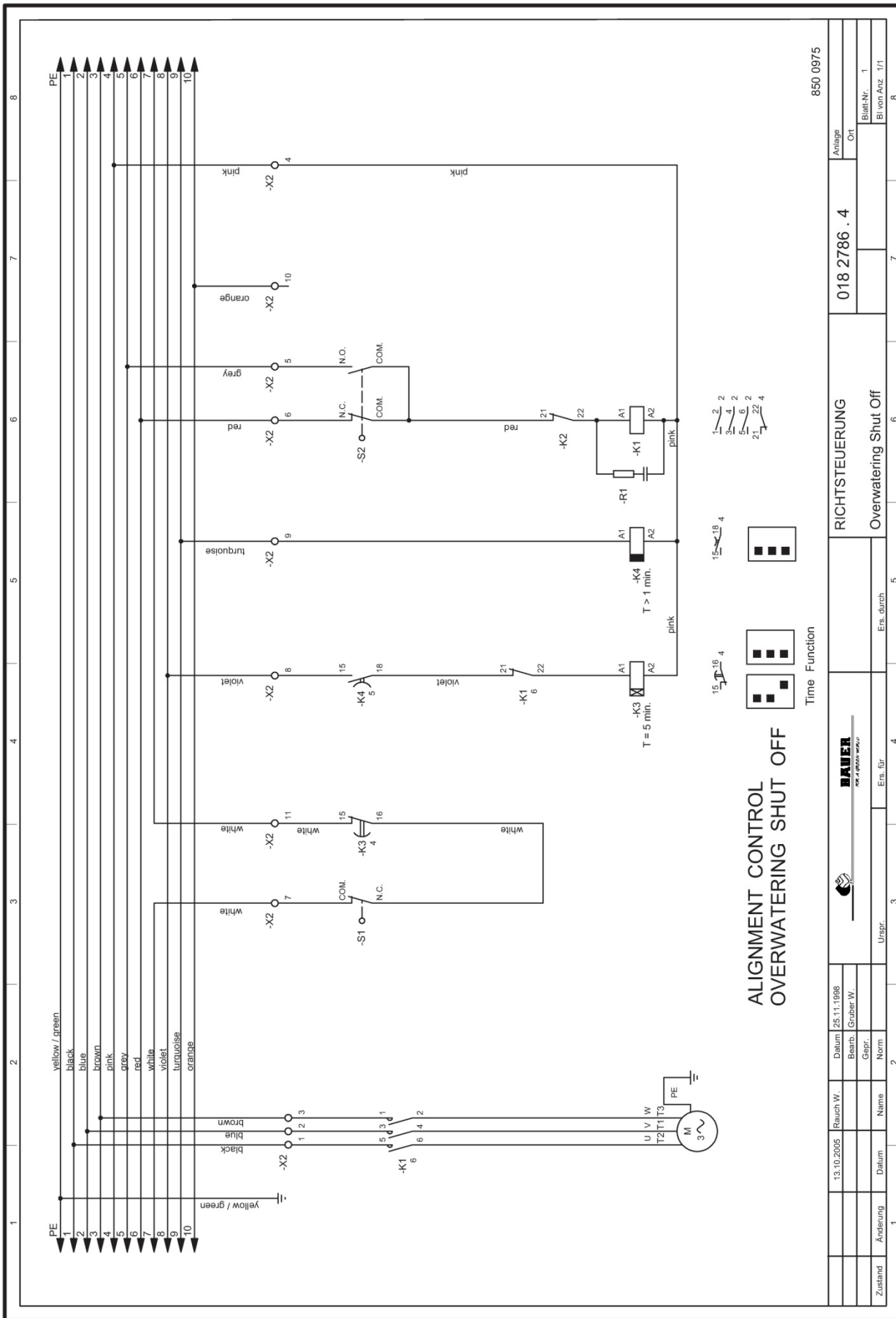

850 0975

Anlage Ort

018 2786 . 4

Blatt-Nr. 1

Bl von Anz. 1/1

8

7

6

5

4

3

2

1

RIGHTSTEUERUNG

Overwatering Shut Off

Time Function

BAUER

13.10.2005

25.11.1998

Reuch W.

Gruber W.

1

24.4.4 ALIGNMENT CONTROL WITH TOWER ALIGNMENT SWITCH AND END TOWER MONITORING DEVICE

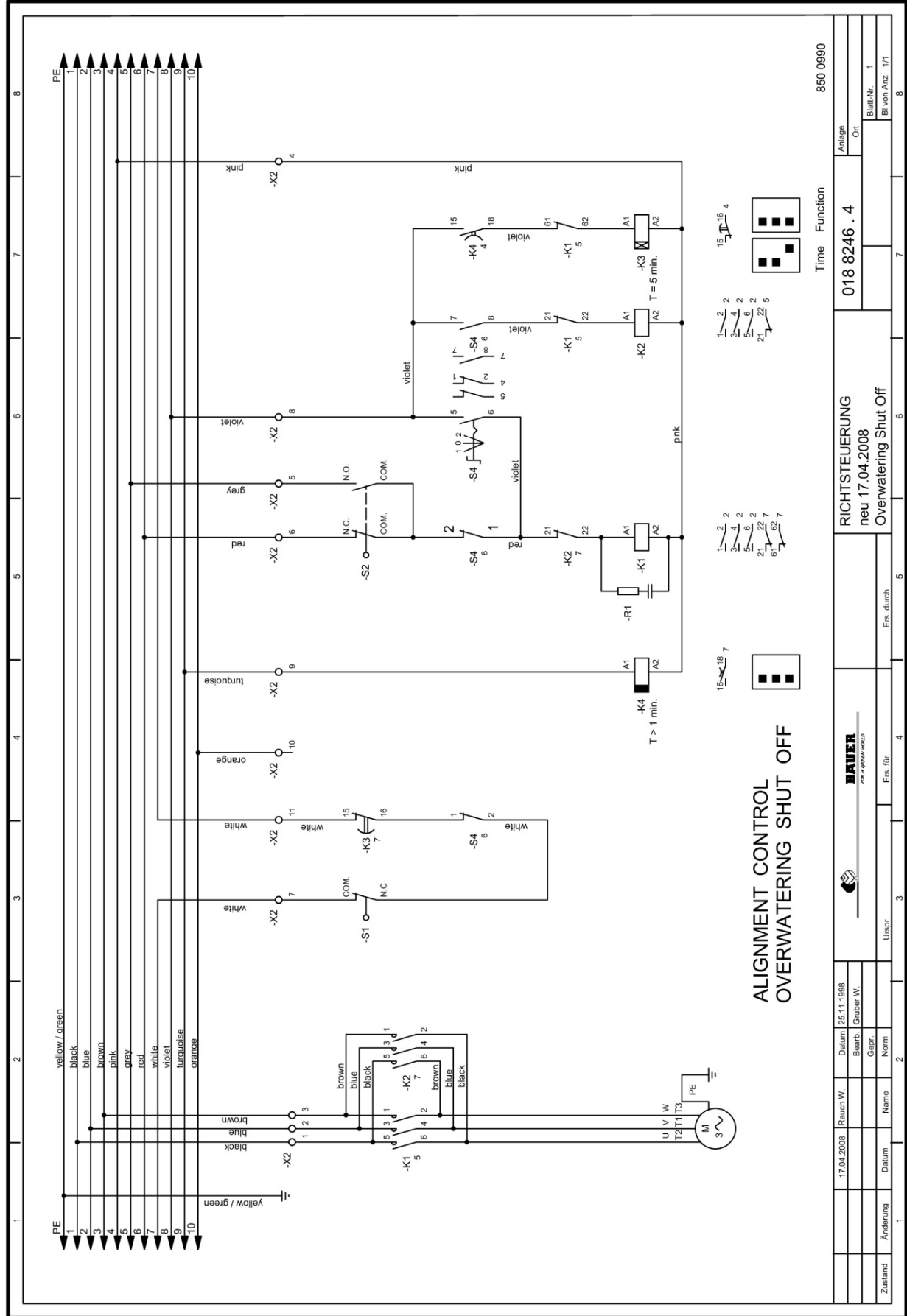



24.4.5 ALIGNMENT CONTROL WITH TOWER ALIGNMENT SWITCH FOR ELECTRIC SWIVELLING OF THE DRIVE TOWER WHEELS

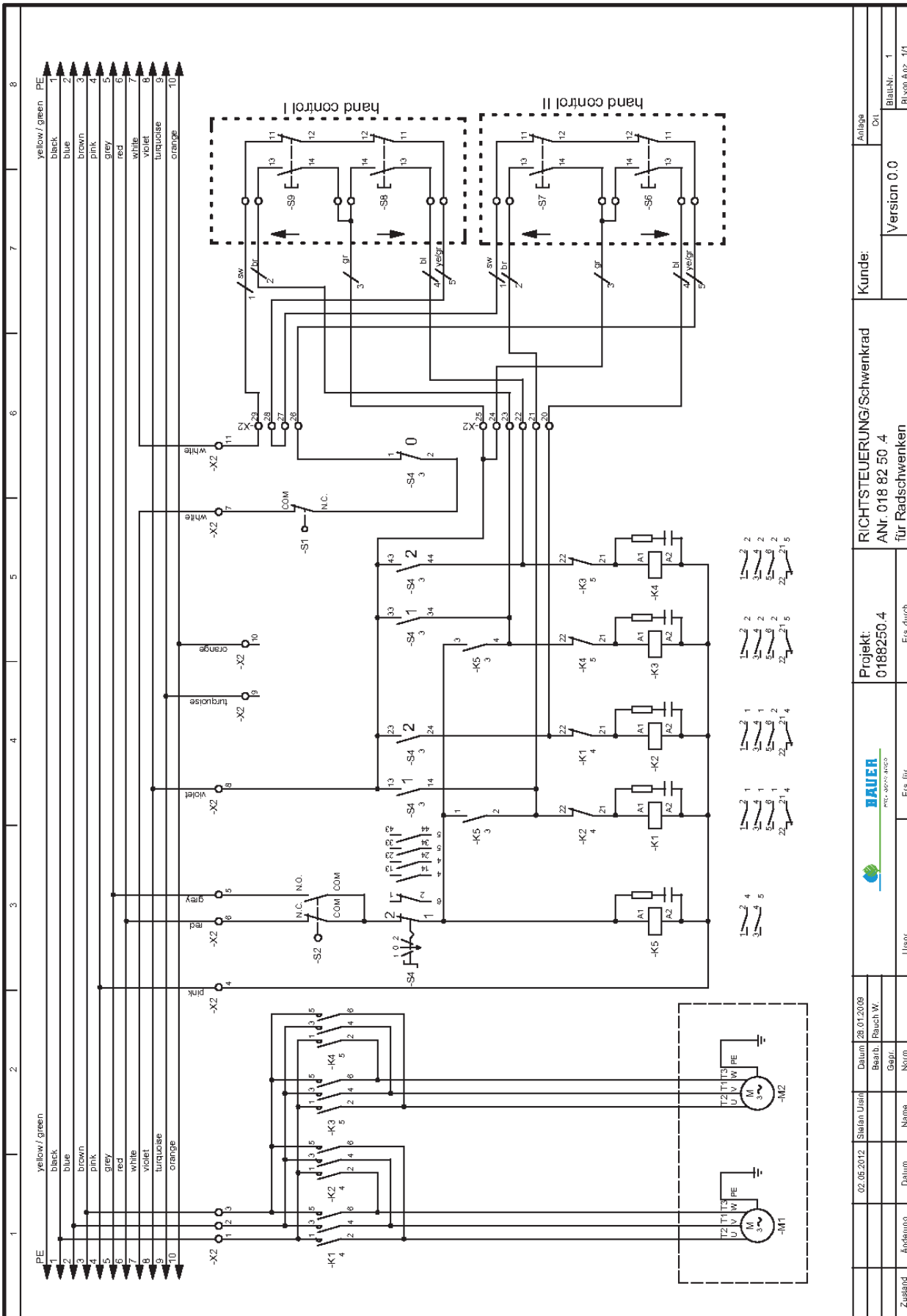

Zustand	Änderung	Datum	Name	Norm	Uspr.	Es ist für	Es ist durch	Projekt:	RICHTSTEUERUNG/Schwenkrad	Kunde:	Anlage
		02.05.2012	Stefan Usini					0189250.4	ANr. 018 82 50_4	Version 0.0	01
								für Radschwenken			BlattNr. 1
											Bl von Anz. 1/1

24.4.6 ALIGNMENT CONTROL WITH TOWER ALIGNMENT SWITCH AND END TOWER MONITORING DEVICE FOR ELECTRIC SWIVELLING OF DRIVE TOWER WHEELS

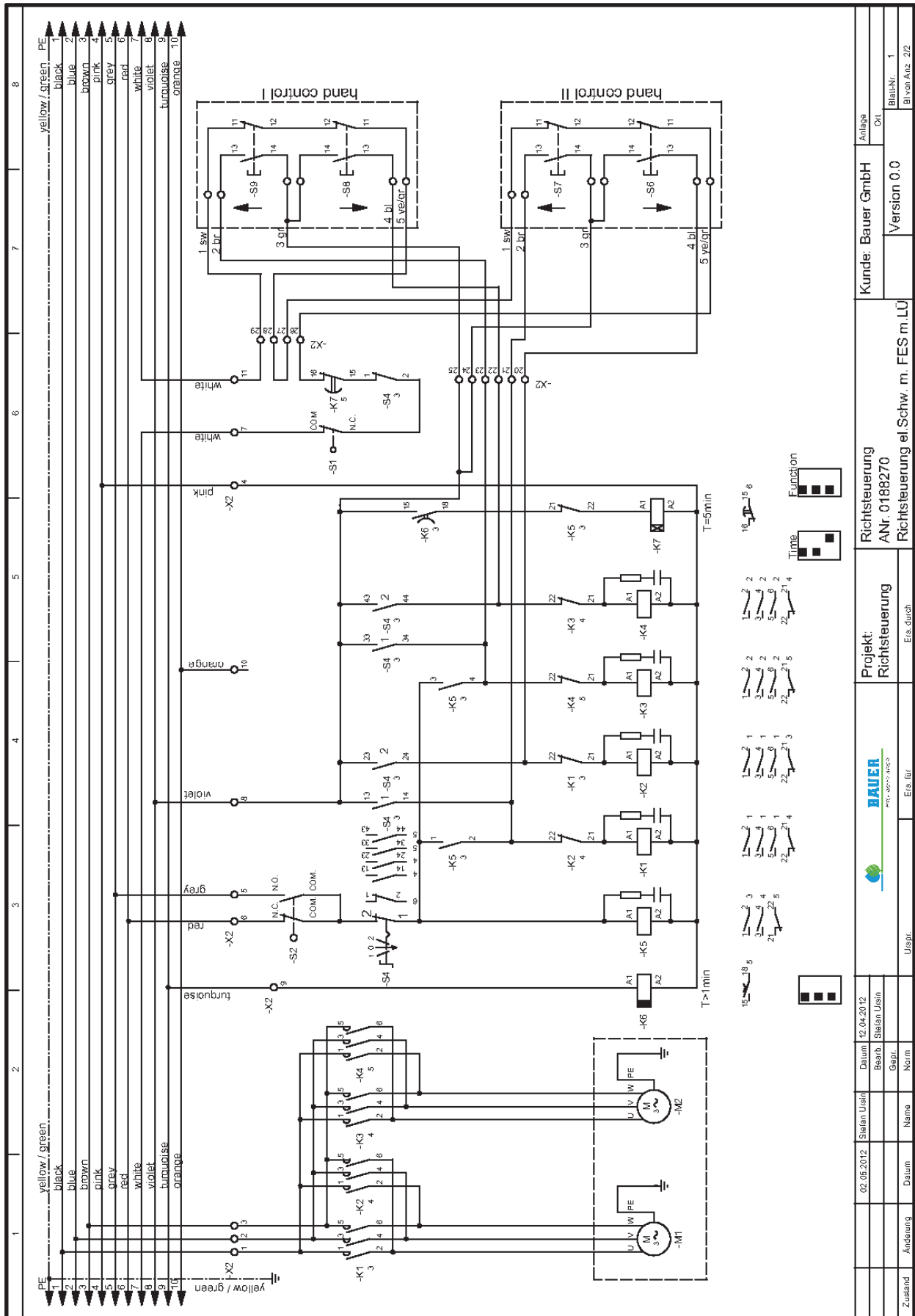

24.4.7 END CONTROL STANDARD

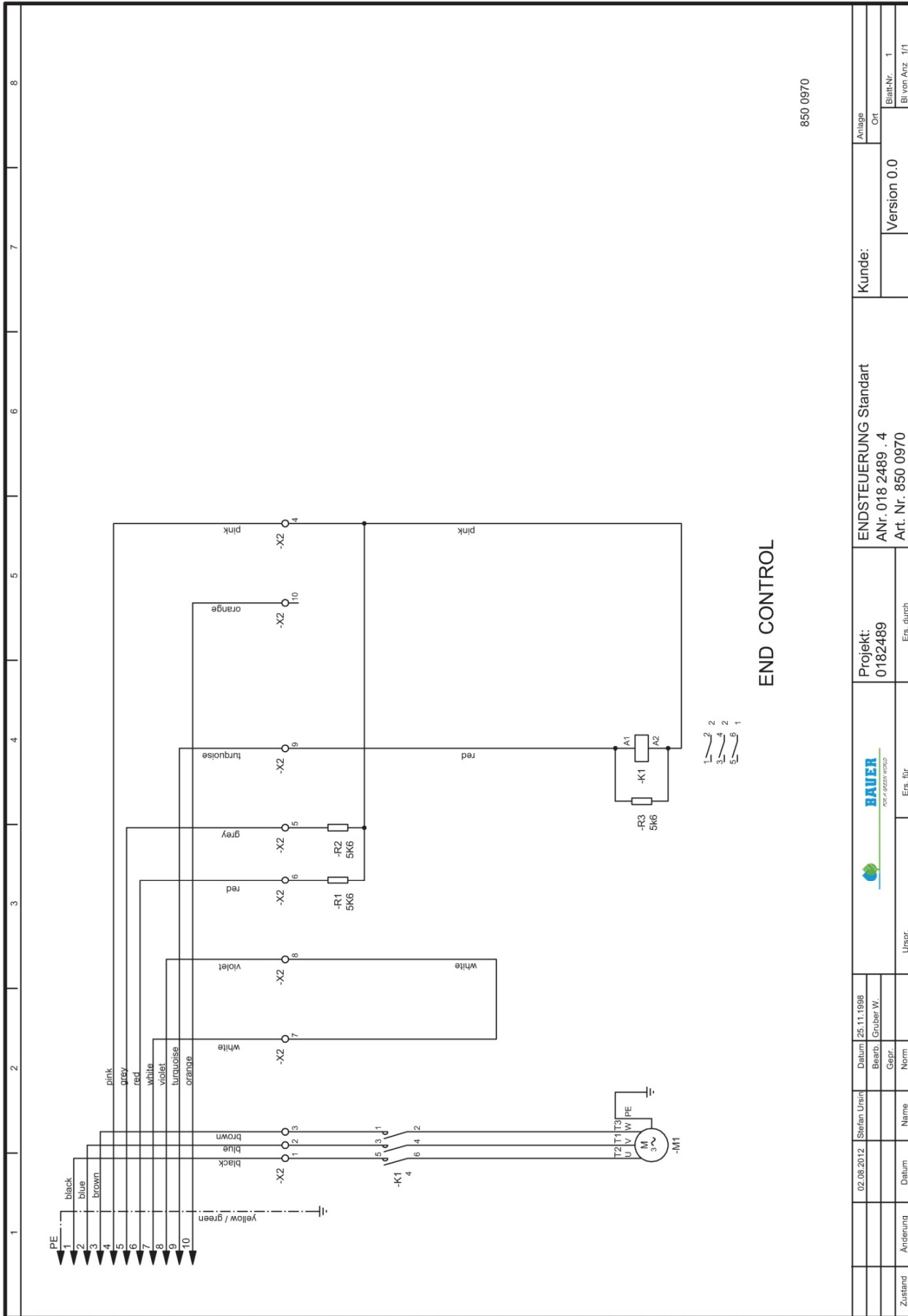

Zustand		Anlage		Kunde:		ENDSTEUERUNG Standard		Blatt-Nr. 1	
Änderung		Ort		Version 0.0		ANr. 018 2489 . 4		Bl. von Anz. 1/1	
Datum		Ers. durch		Ers. für		Art. Nr. 850 0970			
Name		Ers. durch		Ers. für		Projekt:			
Norm		Ers. durch		Ers. für		0182489			
Gepr.		Ers. durch		Ers. für		BAUER			
Datum		Ers. durch		Ers. für		FOR A GREEN WORLD			
Name		Ers. durch		Ers. für		25.11.1988			
Datum		Ers. durch		Ers. für		25.11.1988			
Name		Ers. durch		Ers. für		Stellen Urspr.			
Datum		Ers. durch		Ers. für		02.08.2012			

24.4.8 END CONTROL WITH TOWER ALIGNMENT SWITCH

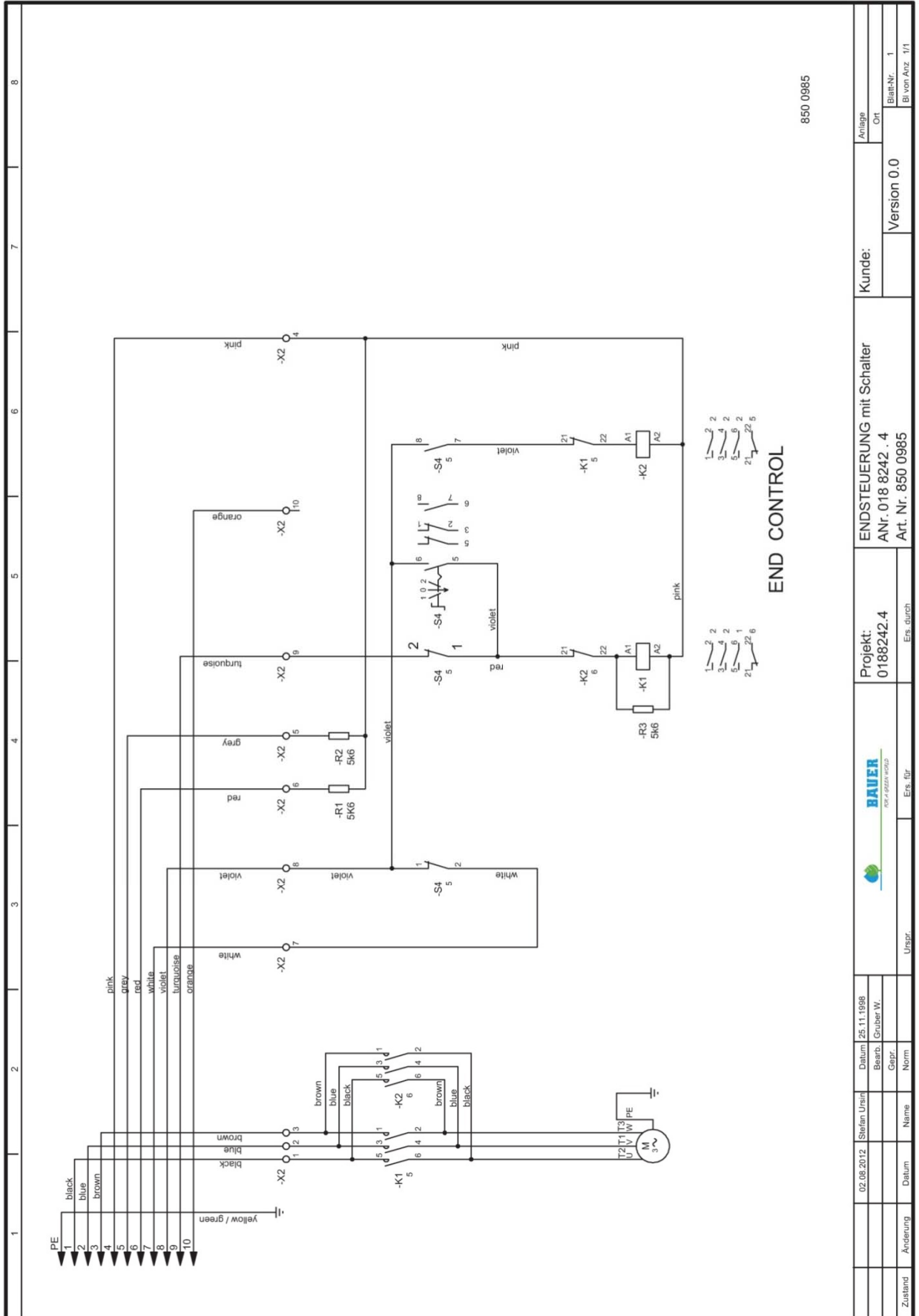

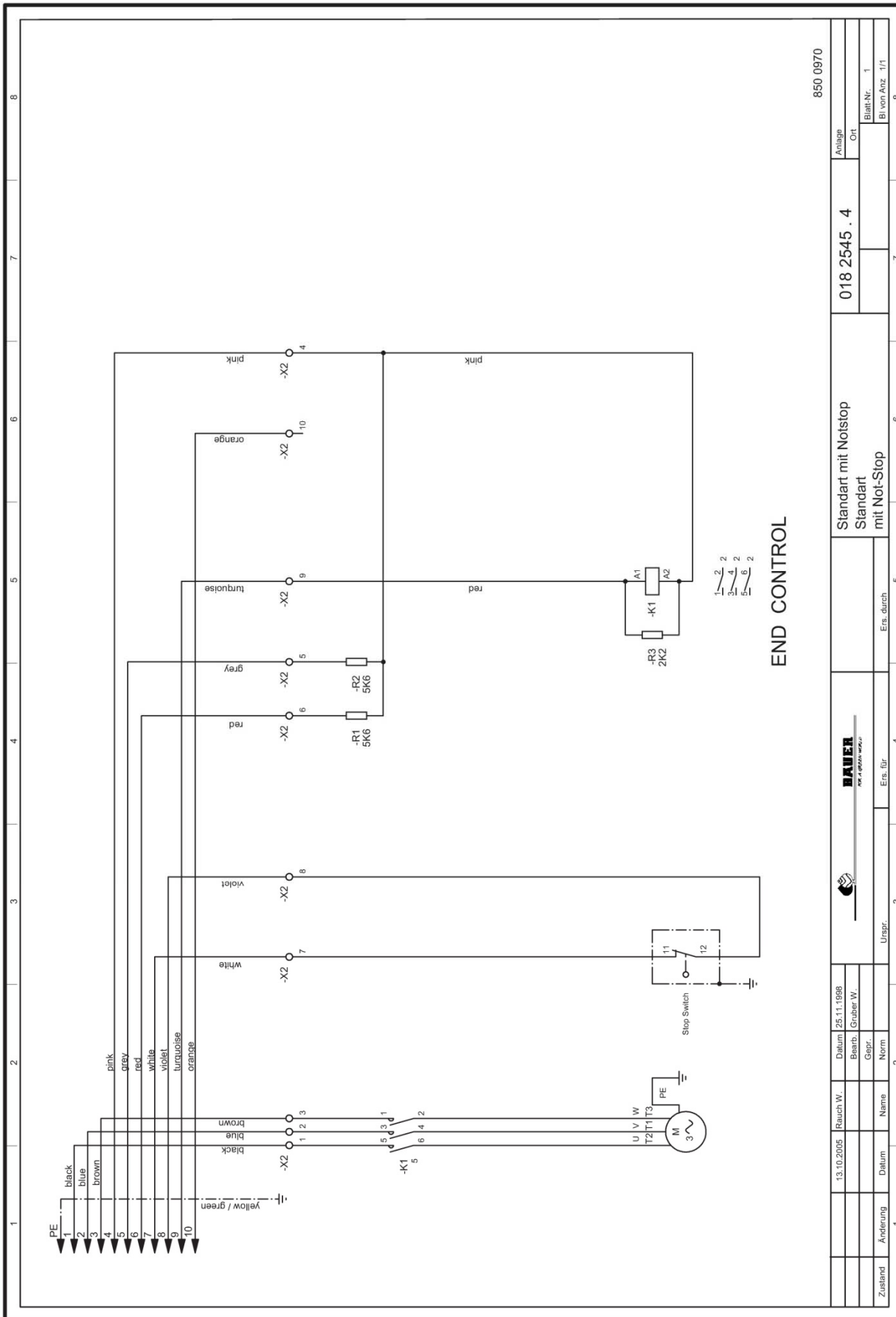

Zustand	Änderung	Datum	Name	Norm	Urspr.	Ers. durch	Art. Nr. 850 0985
		02.08.2012	Stevan Ursini				
		25.11.1998					
		Bearb.	Gruber W.				
		Gepr.					
Projekt: 0188242.4							Ers. durch
Kunde: ENDSTEUERUNG mit Schalter							Art. Nr. 850 0985
Version 0.0							Blatt-Nr. 1
							Bl. von/Anz 1/1

24.4.9 END CONTROL WITH END STOP



850 0970

13.10.2005	Rauch W.	Datum	25.11.1998					Standard mit Notstop Standard mit Not-Stop		018 2545 . 4		Anlage	Blatt-Nr. 1 Bl von Anz 1/1	
Zustand	Änderung	Datum	Name	Gepr.	Bearb.	Grübler W.	Ers. für	Ers. durch	850 0970			Ort		
Urgrpr.														8

24.4.10 END CONTROL WITH END STOP AND TOWER ALIGNMENT SWITCH

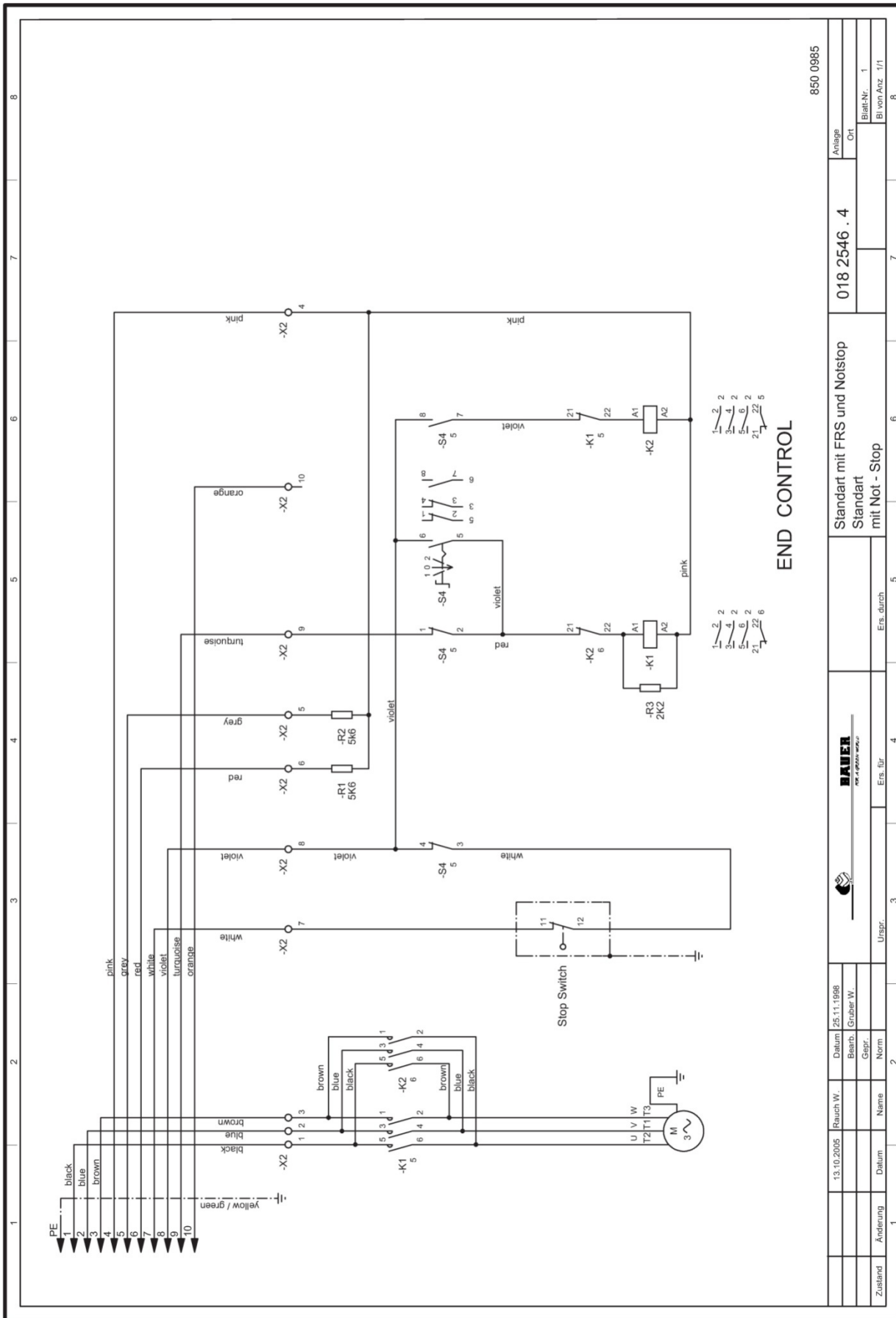

24.4.11 END CONTROL STANDARD WITH END STOP AND AUTOREVERSE

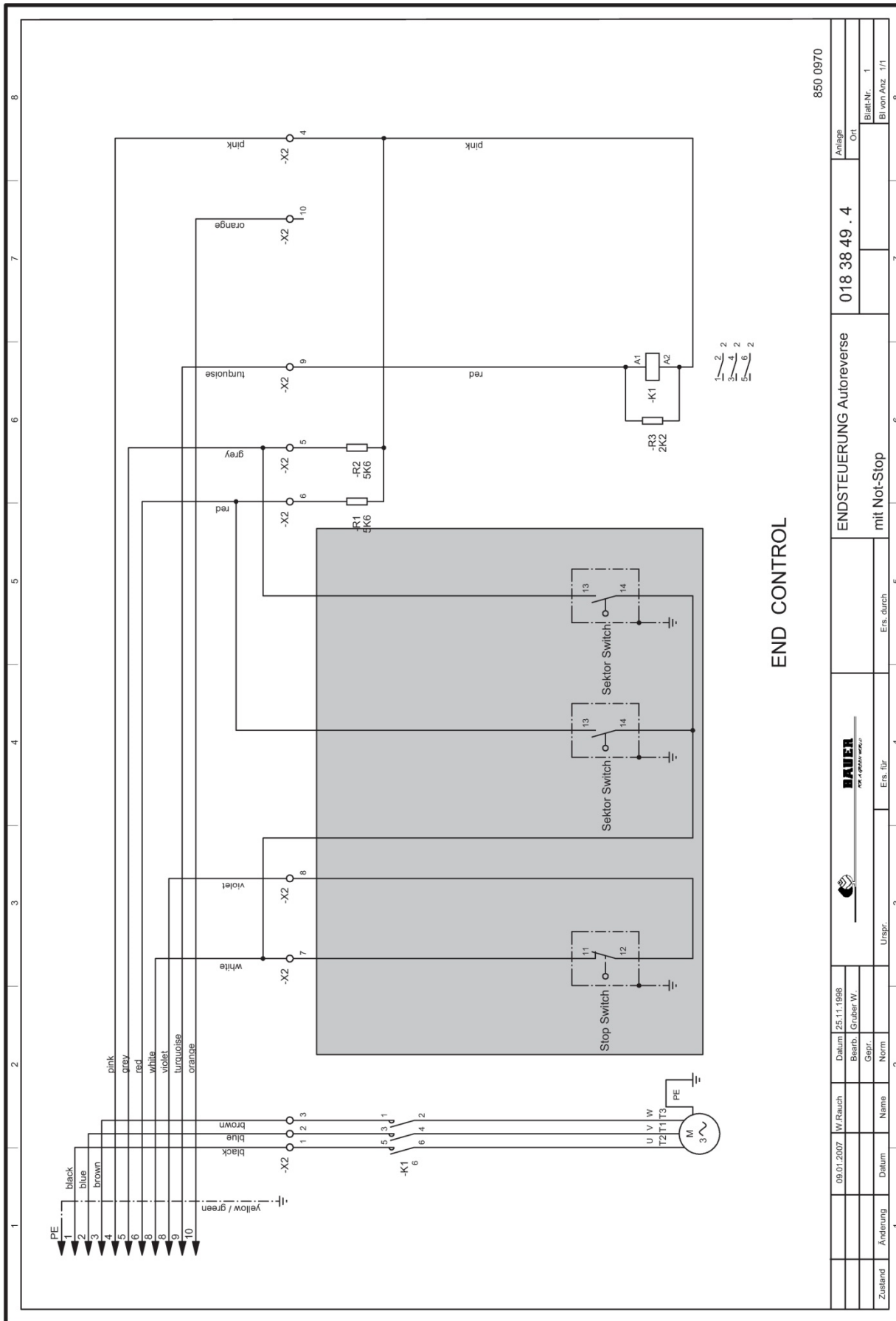

850 0970

Date: 09.01.2007		W. Rauch		Datum: 25.11.1998		W. Rauch		Date: 09.01.2007		W. Rauch		Date: 09.01.2007		W. Rauch		Date: 09.01.2007		W. Rauch	
Author: Gepr. W.		Gepr. W.		Gepr. W.		Gepr. W.		Gepr. W.		Gepr. W.		Gepr. W.		Gepr. W.		Gepr. W.		Gepr. W.	
Name: _____		Name: _____		Name: _____		Name: _____		Name: _____		Name: _____		Name: _____		Name: _____		Name: _____		Name: _____	
Date: _____		Date: _____		Date: _____		Date: _____		Date: _____		Date: _____		Date: _____		Date: _____		Date: _____		Date: _____	
Drawing: _____		Drawing: _____		Drawing: _____		Drawing: _____		Drawing: _____		Drawing: _____		Drawing: _____		Drawing: _____		Drawing: _____		Drawing: _____	
Status: _____		Status: _____		Status: _____		Status: _____		Status: _____		Status: _____		Status: _____		Status: _____		Status: _____		Status: _____	
Plant: _____		Plant: _____		Plant: _____		Plant: _____		Plant: _____		Plant: _____		Plant: _____		Plant: _____		Plant: _____		Plant: _____	
Sheet No.: 1		Sheet No.: 1		Sheet No.: 1		Sheet No.: 1		Sheet No.: 1		Sheet No.: 1		Sheet No.: 1		Sheet No.: 1		Sheet No.: 1		Sheet No.: 1	
Bl von Anz: 1/1		Bl von Anz: 1/1		Bl von Anz: 1/1		Bl von Anz: 1/1		Bl von Anz: 1/1		Bl von Anz: 1/1		Bl von Anz: 1/1		Bl von Anz: 1/1		Bl von Anz: 1/1		Bl von Anz: 1/1	

24.4.12 END CONTROL WITH DRIVE TOWER ALIGNMENT SWITCH WITH END STOP AND AUTOREVERSE

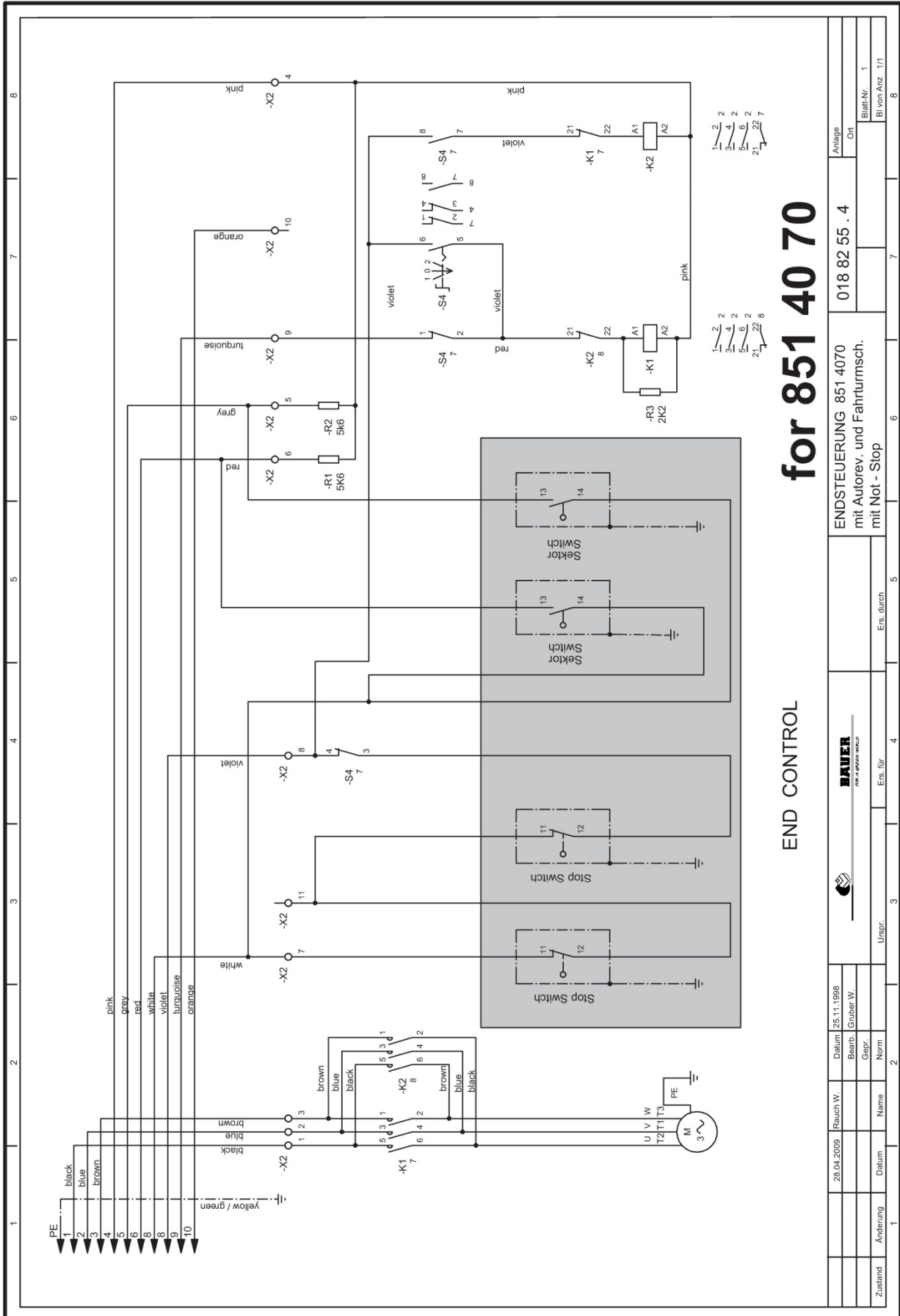

for 851 40 70

END CONTROL

Zustand	Änderung	Datum	Name	Norm	Ungpr.	Ers. für	Ers. durch	018 82 55 . 4	
		28.04.2009	Rauch W.					ENDSTEUERUNG 851 4070	
			Bearb. Graber W.					mit Autorev. und Fahrumsch.	
								mit Not-Stop	
								Anlage	Ort
								Blatt-Nr. 1	Bl. von Anz. 1/1



24.4.13 END CONTROL WITH DRIVE TOWER ALIGNMENT SWITCH FOR ELECTRIC SWIVELLING OF THE DRIVE TOWER WHEELS

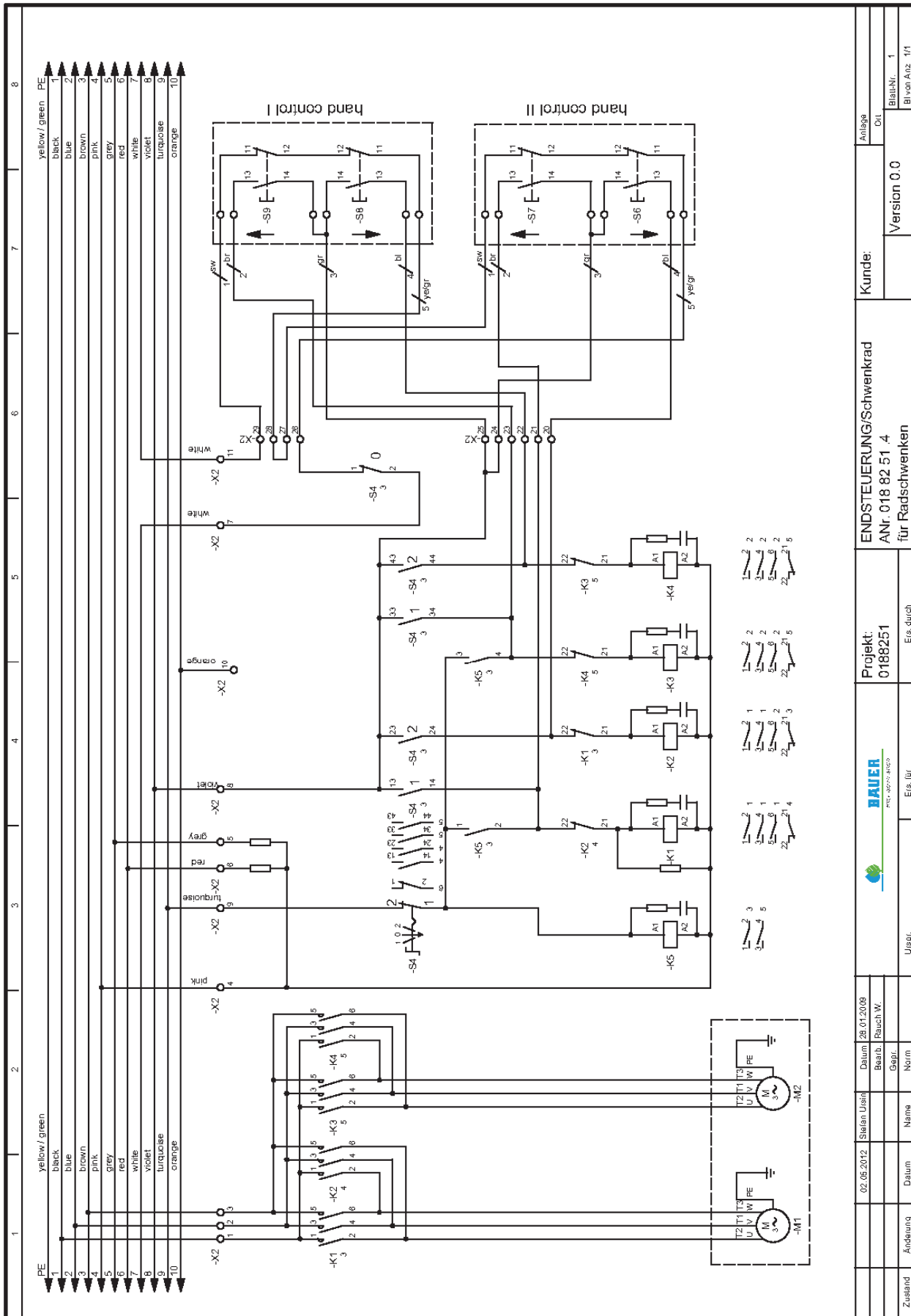

Zustand		Änderung		Datum		Name		Uspr.		Ers. für		Ers. durch		Projekt: 0188251		ENDSTEUERUNG/Schwenzrad ANr. 018 82 51 4 für Radschwenzen		Kunde:		Version 0.0		Anlage Dtl.		BlattNr. 1		Bl-von Anz. 1/1	

24.5 BOOSTER PUMP FOR END GUN

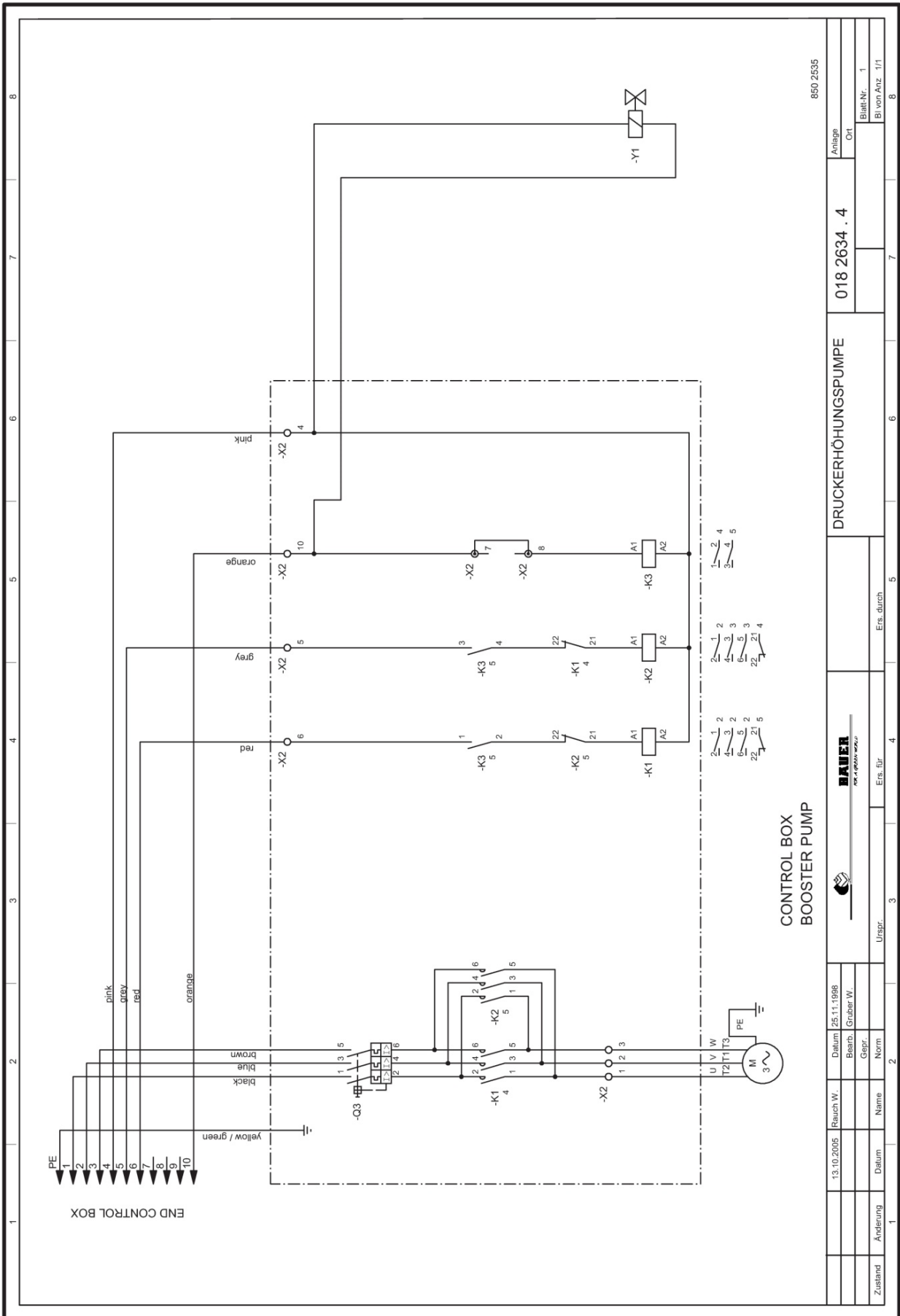



25 SERVICE PROOF

Has been done					
	Yes	No	Date	Operating hours	Proof for the accomplished service
Part -Service					
Part -Service					
Part -Service					
Part -Service					
Part -Service					
Part -Service					
Part -Service					
Part -Service					
Part -Service					
Part -Service					
Part-Service					
Oil change-Service					
Annual-Service					

Has been done					
	Yes	No	Date	Operating hours	Proof for the accomplished service
Part -Service					
Part -Service					
Part -Service					
Part -Service					
Part -Service					
Part -Service					
Part -Service					
Part -Service					
Part -Service					
Part -Service					
Part -Service					
Part -Service					
Oil change-Service					
Annual Service					



Has been done					
	Yes	No	Date	Operating hours	Proof for the accomplished service
Part -Service					
Part -Service					
Part -Service					
Part -Service					
Part -Service					
Part -Service					
Part -Service					
Part -Service					
Part -Service					
Part -Service					
Part -Service					
Oil change-Service					
Annual-Service					

Has been done					
	Yes	No	Date	Operating hours	Proof for the accomplished service
Part -Service					
Part -Service					
Part -Service					
Part -Service					
Part -Service					
Part -Service					
Part -Service					
Part -Service					
Part -Service					
Part -Service					
Part -Service					
Oil change-Service					
Annual Service					



Has been done					
	Yes	No	Date	Operating hours	Proof for the accomplished service
Part -Service					
Part -Service					
Part -Service					
Part -Service					
Part -Service					
Part -Service					
Part -Service					
Part -Service					
Part -Service					
Part -Service					
Part -Service					
Oil change-Service					
Annual-Service					

Has been done					
	Yes	No	Date	Operating hours	Proof for the accomplished service
Part -Service					
Part -Service					
Part -Service					
Part -Service					
Part -Service					
Part -Service					
Part -Service					
Part -Service					
Part -Service					
Part -Service					
Part -Service					
Oil change-Service					
Annual Service					



Has been done					
	Yes	No	Date	Operating hours	Proof for the accomplished service
Part -Service					
Part -Service					
Part -Service					
Part -Service					
Part -Service					
Part -Service					
Part -Service					
Part -Service					
Part -Service					
Part -Service					
Part -Service					
Oil change-Service					
Annual-Service					

Has been done					
	Yes	No	Date	Operating hours	Proof for the accomplished service
Part -Service					
Part -Service					
Part -Service					
Part -Service					
Part -Service					
Part -Service					
Part -Service					
Part -Service					
Part -Service					
Part -Service					
Part -Service					
Oil change-Service					
Annual Service					



26 CONFORMITY CERTIFICATE

EC Declaration of Conformity

according to EC Directive 2006/42/EG

The manufacturer

Röhren- und Pumpenwerk BAUER Gesellschaft m.b.H.
Kowaldstraße 2, 8570 Voitsberg, Austria
Tel: +43 3142 200-0; Fax: +43 3142 200-320/-340

herewith confirms that the machine mentioned below

Designation of machine	BAUER CENTERLINER 9000
Machine type / basic units	168 CLS, 168 CLE, 168 CLX

corresponds analogously to the requirements of the Machinery Directive 2006/42/EG.

In case of modification of the machine not accorded with BAUER GmbH, this declaration will cease to be valid.

The following standards as amended have been applied analogously:

DIN EN ISO 12100-1	Safety of machinery - Basic concepts, general principles for design Part 1: Basic terminology, methodology
DIN EN ISO 12100-2	Safety of machinery - Basic concepts, general principles for design Part 2: Technical principles
DIN EN 60204-1	Safety of machinery - Electrical equipment of machines Part 1: General requirements
EN ISO 14121-1	Safety of machinery - Risk assessment Part 1: Principles
ÖNORM EN ISO 13857	Safety of machinery - Safety distances to prevent hazard zones being reached by upper and lower limbs

Standards related to products

DIN EN 909	Agricultural and forestry machinery - Centre pivot and moving lateral types irrigation machines - Safety
------------	---

Person in charge of documentation: Thomas Theissl, Kowaldstraße 2, 8570 Voitsberg, Austria,

Technical Designer in Charge

BAUER
Gesellschaft m.b.H.
A-8570 Voitsberg / Austria

Commercial Manager

Voitsberg, 24.05.2013